



UNIVERSITY OF CAMBRIDGE INTERNATIONAL EXAMINATIONS  
General Certificate of Education  
Advanced Subsidiary Level and Advanced Level

www.PapaCambridge.com

**DESIGN AND TECHNOLOGY**

**9705/13**

Paper 1

**October/November 2012**

**3 hours**

Additional Materials: Answer Booklet/A4 Paper  
A3 Drawing Paper (2 sheets)  
Extra sheets of A3 drawing paper for candidates who have used up both sides of their 2 sheets  
A range of design drawing equipment

\* 8 7 3 2 4 9 7 8 0 4 \*

**READ THESE INSTRUCTIONS FIRST**

If you have been given an Answer Booklet, follow the instructions on the front cover of the Booklet.  
Write your answers and working on the separate Answer Booklet/Paper provided.  
Write your name, Centre number and candidate number on all the work you hand in.  
Write in dark blue or black pen.  
You may use a soft pencil, or coloured pencils/pens as appropriate, for any diagrams, graphs or rough working.  
Do not use staples, paper clips, highlighters, glue or correction fluid.  
**DO NOT WRITE ON ANY BARCODES.**

**Section A**

Answer **one** question on the Answer Booklet/A4 Paper provided.

**Section B**

Answer **one** question on the Answer Booklet/A4 Paper provided.

**Section C**

Answer **one** question on plain A3 paper.  
Use **both** sides of the paper.  
You may request additional sheets of A3 paper, but only if you have used both sides of each of the 2 sheets provided.

You are advised to spend **30 minutes** on each of Sections A and B and **2 hours** on Section C.

At the end of the examination, fasten all your work securely together.  
The number of marks is given in brackets [ ] at the end of each question or part question.  
All dimensions are in millimetres.

This document consists of **10** printed pages and **2** blank pages.



## Section A

Answer **one** question from this section on the Answer Booklet/A4 paper provided.

- 1 Fig. 1 shows a toolbox which is to be made in a school workshop.

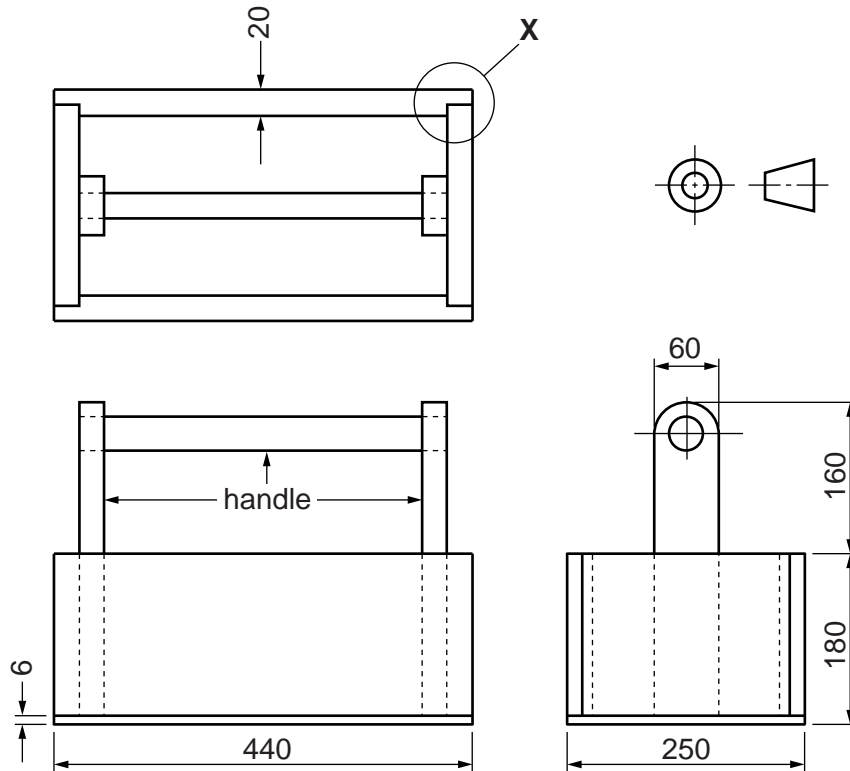

Fig. 1

- (a) Name a suitable:
- (i) softwood for making the four sides of the toolbox; [1]
  - (ii) sheet material for making the bottom of the toolbox. [1]
- (b) Use notes and sketches to describe:
- (i) how the three parts of the handle could be made and assembled; [6]
  - (ii) how the joint shown at X could be made; [6]
  - (iii) how the bottom of the toolbox could be glued and nailed to the sides. [6]

You must give details about the tools, equipment and processes involved and the safety precautions that have to be undertaken at each stage.

2 Fig. 2 shows a desk tidy which is to be made in a school workshop.

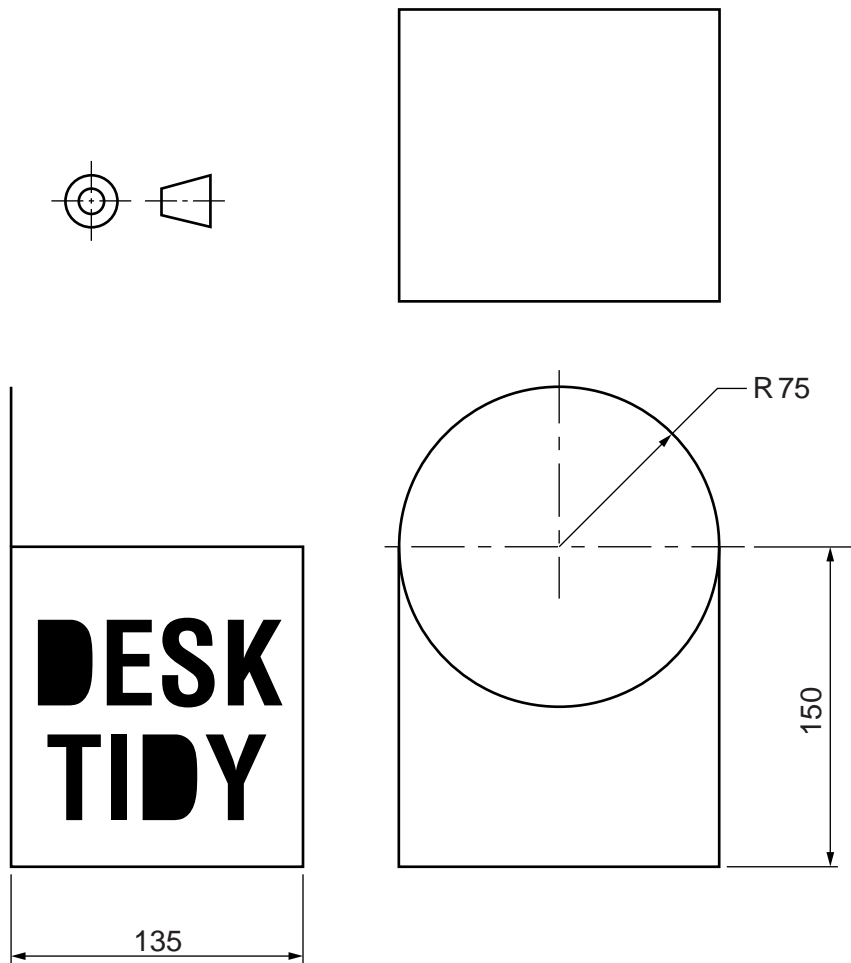
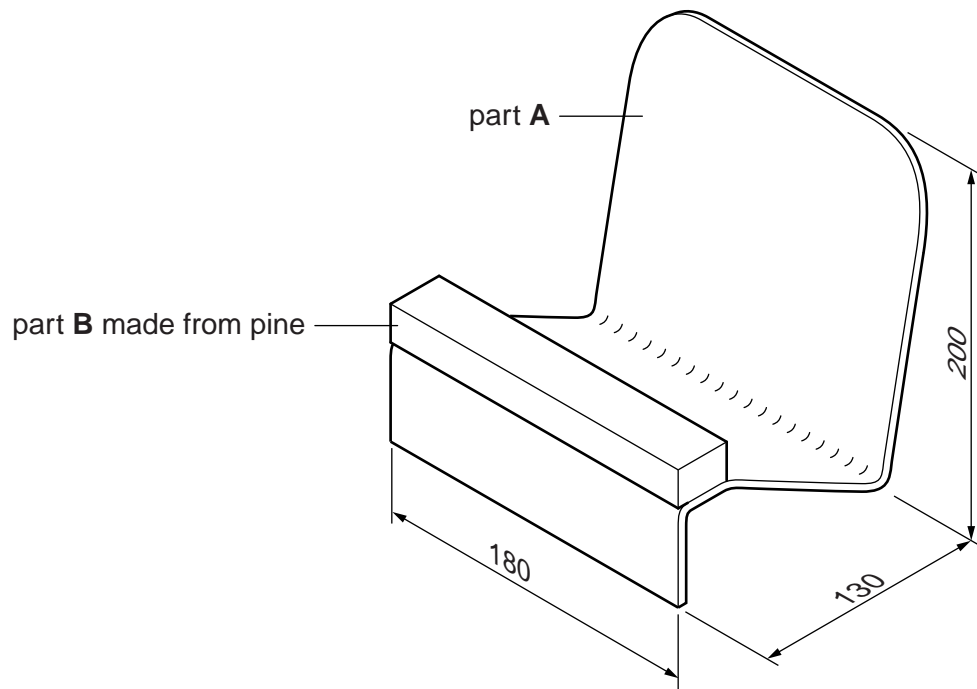

Fig. 2

- (a) The desk tidy is made from one piece of card with the corners glued together.  
Sketch to an appropriate scale, the development (net) required to make the desk tidy. [6]
- (b) Two pieces of corrugated cardboard will be slotted together to make four compartments in the assembled desk tidy.  
Use notes and a sketch to explain what corrugated cardboard looks like. [2]
- (c) Use notes and sketches to describe how the two pieces of corrugated cardboard could:
  - (i) be cut out; [2]
  - (ii) have the slots cut in them; [2]
  - (iii) be assembled. [2]
- (d) Use notes and sketches to describe how a stencil could be made and used to add the lettering to the desk tidy. [6]

You must give details about the tools, equipment and processes involved and the safety precautions that have to be undertaken at each stage.

- 3 Fig. 3 shows a book rest which is to be made in a school workshop.



**Fig. 3**

- (a) Name a suitable sheet material for making part **A** and give **one** reason for your choice. [2]
- (b) Use notes and sketches to describe:
- (i) how part **A** could be cut out and the edges of the sheet material smoothed; [6]
  - (ii) how part **A** could be bent to the required shape; [6]
  - (iii) how part **A** could be joined to part **B** using countersunk screws. [6]

You must give details about the tools, equipment and processes involved and the safety precautions that have to be undertaken at each stage.

## Section B

Answer **one** question from this section on the Answer Booklet/A4 paper provided.

- 4 Fig. 4 shows a design for part of a child's activity sheet. The activity sheet will be printed on the back of cereal boxes. A child will cut out the two parts, colour them in and slot them together to make a model of a bird.

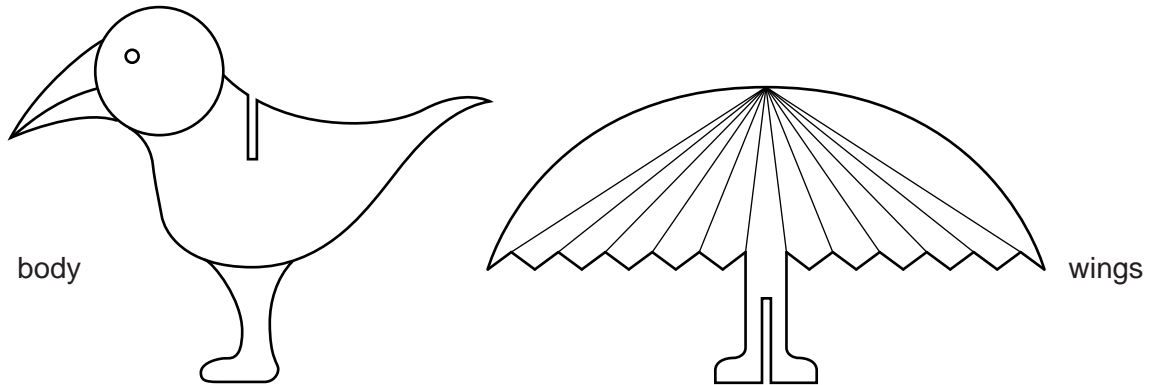

Fig. 4

- (a) Identify and describe **two** problems with the design. [4]
- (b) Using notes and sketches, explain how the design would need to be changed to overcome the two problems that you have identified in (a). [6]
- (c) Fig. 5 shows two symbols printed on the cereal box.

State the meaning of each of these symbols. [2]

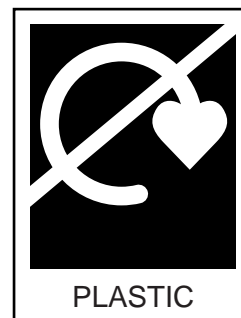
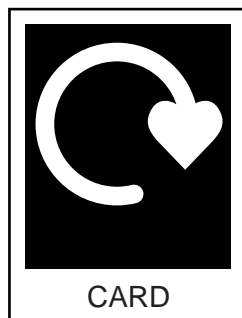

Fig. 5

- (d) Discuss how and why manufacturers are designing packaging for reuse and recycling.

Your answer should:

- (i) analyse the given situation and identify three relevant issues raised by the question; [3]
- (ii) explain why you consider these three issues to be relevant; [3]
- (iii) contain specific examples/evidence as support for your conclusions. [2]

5 Fig. 6 shows an eyewash station.

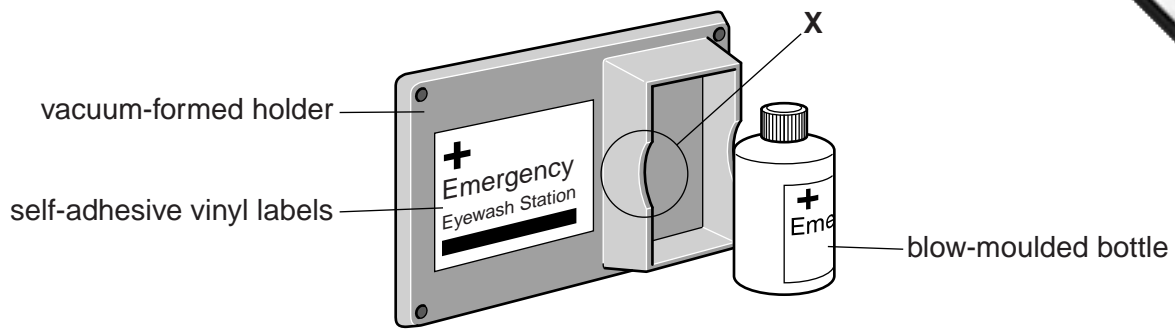
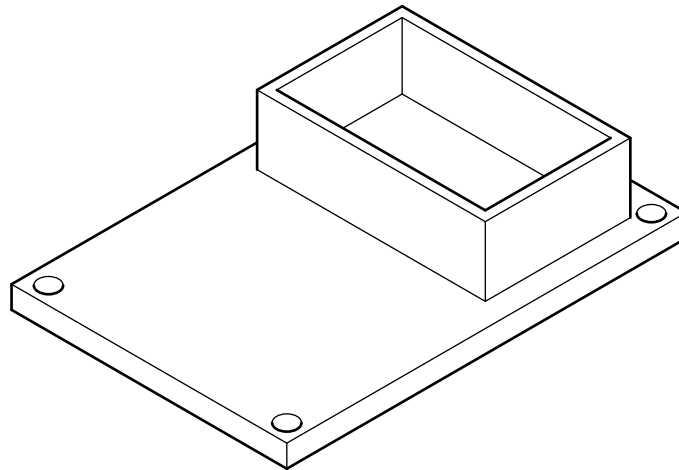

**Fig. 6**

(a) Explain the function of the design feature shown at **X**. [2]

(b) Fig. 7 shows a design for the former required to make the vacuum-formed holder.

Identify and describe **two** problems with the design of the former. [4]



**Fig. 7**

(c) Using notes and sketches, explain how the design would need to be changed to overcome the two problems you have identified in (b). [6]

(d) The eyewash station has been made from various types of plastic.

Discuss why plastic is often referred to as a 'non-renewable material'.

Your answer should:

- (i) analyse the given situation and identify three relevant issues raised by the question; [3]
- (ii) explain why you consider these three issues to be relevant; [3]
- (iii) contain specific examples/evidence as support for your conclusions. [2]

- 6 Fig. 8 shows a range of designs for nesting tables and a knock-down (temporary) fitting.

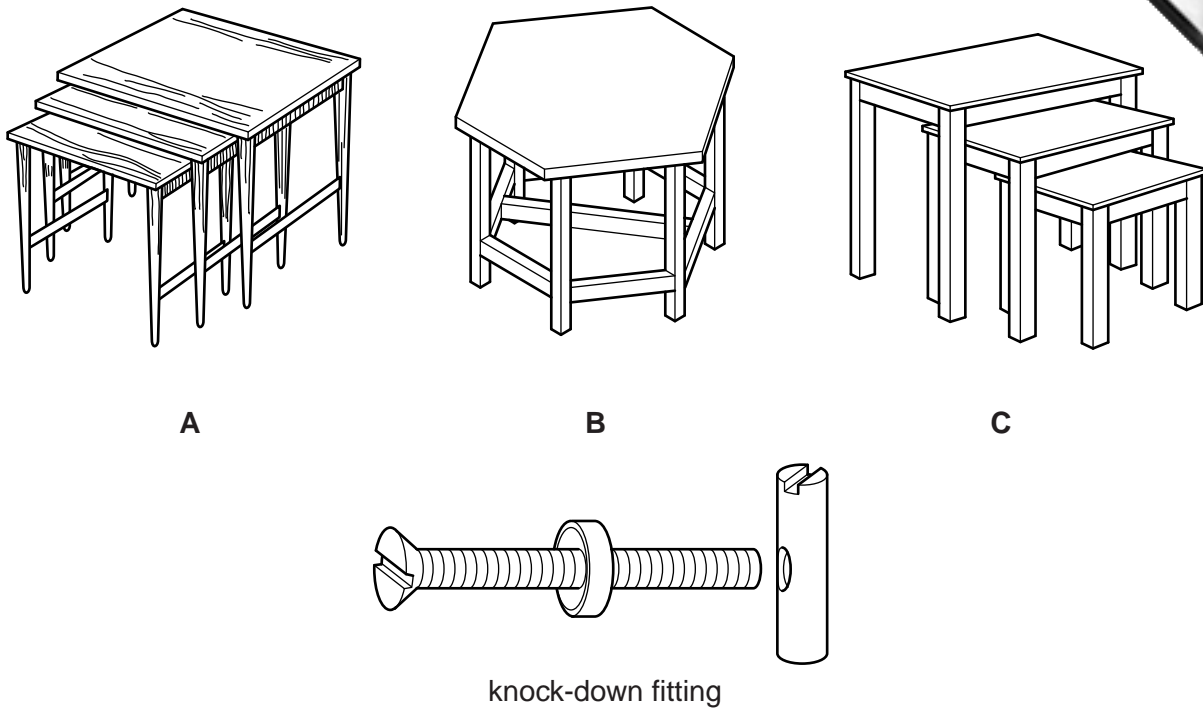

**Fig. 8**

- (a) Use notes and a sketch to explain how the knock-down fitting could be used to join together two parts of design **A**. [2]
- (b) Identify and describe **two** problems with design **B** that make the design unsuitable for a nesting table. [4]
- (c) Using notes and sketches, explain how the design would need to be changed to overcome the two problems that you have identified in (b). [6]
- (d) Discuss the merits of using knock-down fittings in the mass production of furniture.

Your answer should:

- (i) analyse the given situation and identify three relevant issues raised by the question; [3]
- (ii) explain why you consider these three issues to be relevant; [3]
- (iii) contain specific examples/evidence as support for your conclusions. [2]

## Section C

Answer **one** question from this section on the plain A3 paper provided.

You are provided with two sheets of plain A3 paper. You should use **both** sides of the paper. **Each** of the four parts **(a)–(d)** of the question you choose to answer should take up one side of the paper.

When you are asked to **develop** a design you must show, using notes and sketches, the development and evaluation of a **range** of ideas into a single design proposal. The design proposal should be annotated to give details about materials, joining methods and important sizes.

- 7 Fig. 9 shows an incomplete design for an information desk which will be used in a hotel's reception area.

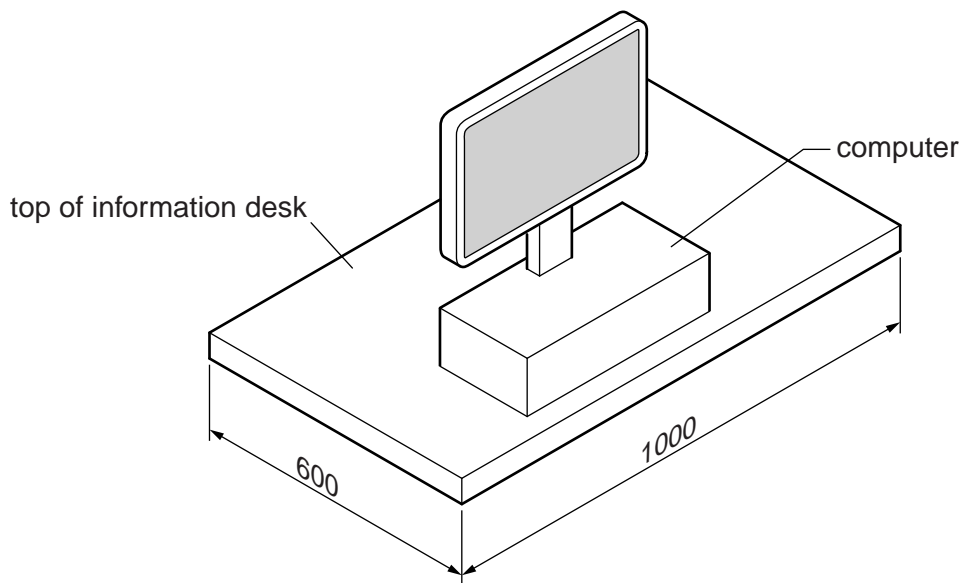

**Fig. 9**

- (a) Using notes and sketches, develop a design for a frame made from metal tube which will support the top of the information desk at a height of 700 mm. [20]
- (b) Using notes and sketches, develop a design for a pull-out shelf to go under the desk. The shelf must be 500 mm wide and will be used to hold a keyboard. The shelf must push back under the desk when not in use. [20]
- (c) Using notes and sketches, develop a design for a unit to hold leaflets about local facilities and places of interest to visit. The unit must hold several copies of 20 different leaflets, each leaflet is 100 mm × 210 mm. The unit will stand on top of the information desk. [20]
- (d) Produce a pictorial rendered drawing of the complete information desk which shows all of the features that you have designed in **(a)–(c)**.

Do not include the computer, the keyboard or the leaflets in this drawing.

[20]



- 8 Fig. 10 shows two types of chocolate and an incomplete idea for a card box in which they are to be packaged.

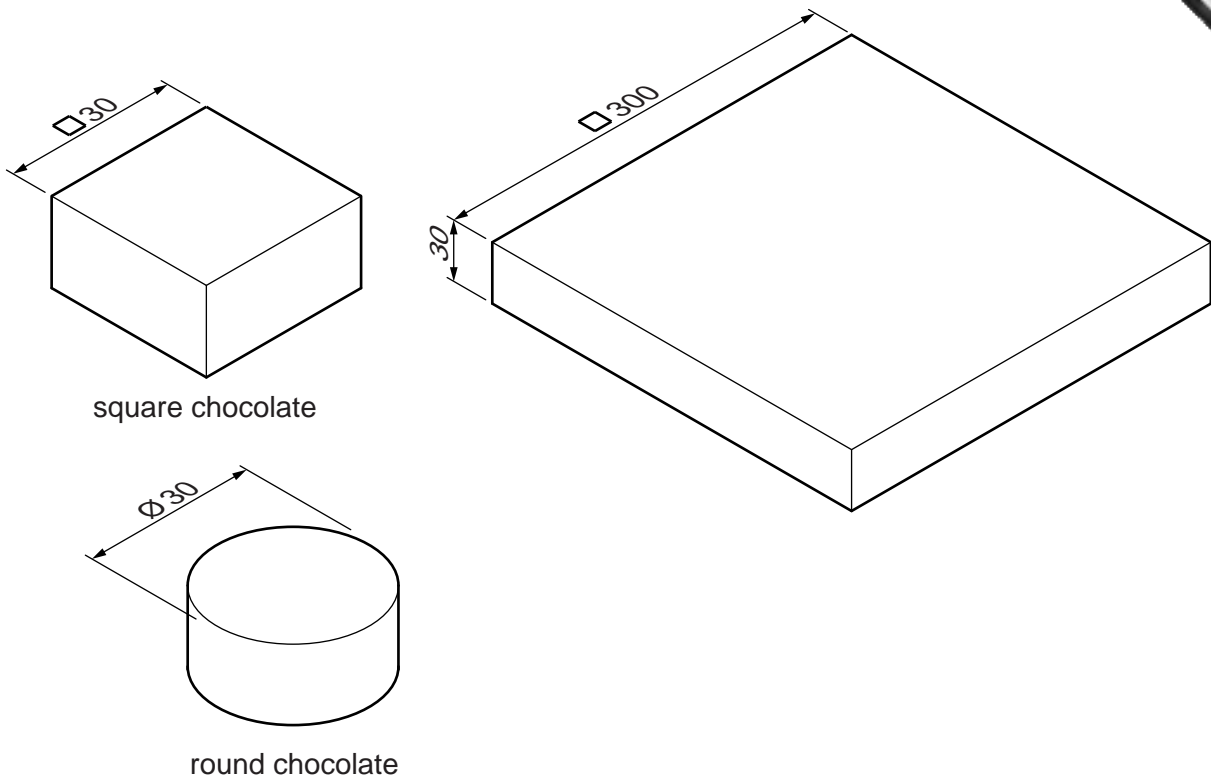

Fig. 10

- (a) Using notes and sketches, develop a design for a plastic insert which will hold 10 square and 10 round chocolates and prevent them moving around in the box. [20]
- (b) Using notes and sketches, develop a design for the card box. The box must be made from a one-piece development (net) and include at least five windows so that at least some of the chocolates can be seen while still in the closed box. It must be possible to open and close the box. [20]
- (c) Using notes and sketches, develop a design for the lettering to go on the packaging. The name of the chocolates will be '**Squares and Rounds**' and the lettering should be in a style that reflects the name. [20]
- (d) Produce an exploded pictorial rendered drawing of the complete packaging which shows all of the features that you have designed in (a)–(c).

Do not include the chocolates in this drawing.

[20]

- 9 Fig. 11 shows an incomplete design for a bird feeding table.

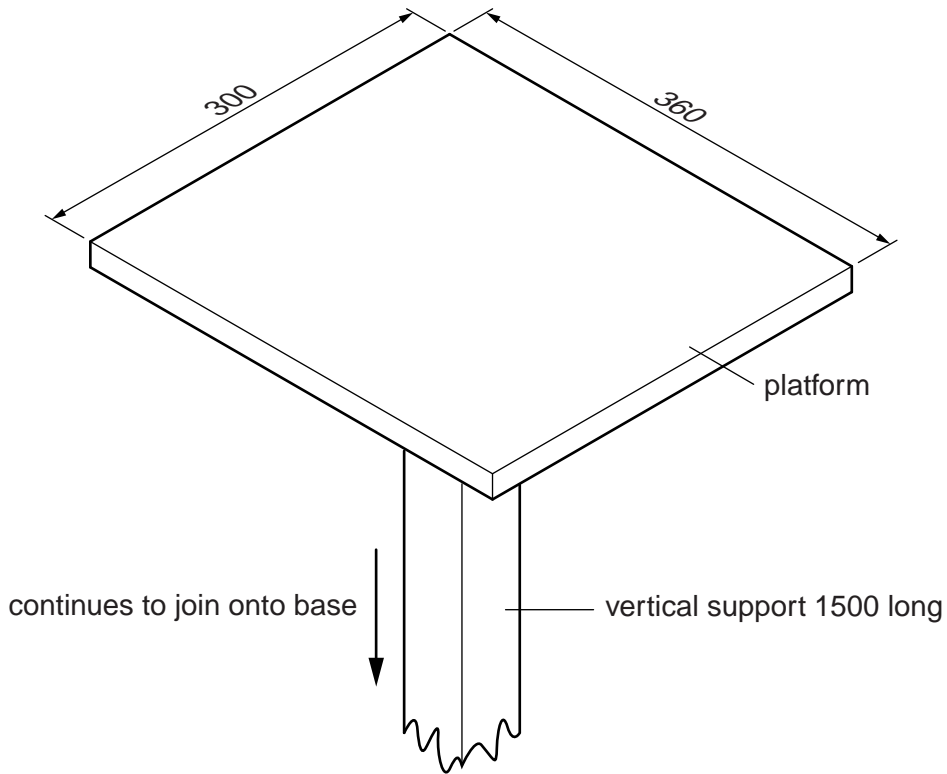
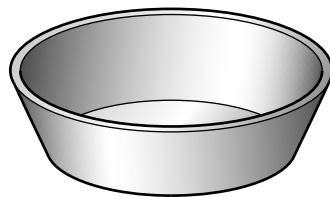

Fig. 11

- (a) Using notes and sketches, develop a design for the base of the bird feeding table. The base must keep the bird feeding table stable but not be permanently fixed to the ground. [20]
- (b) Using notes and sketches, develop a design for a roof for the platform. The roof must allow birds easy access to the platform and be easily removed so the platform can be cleaned. [20]
- (c) Using notes and sketches, develop a design which allows the water bowl shown in Fig. 12 to be easily attached to and removed from the vertical support. [20]



water bowl  
diameter 200 depth 60

Fig. 12

- (d) Produce a pictorial rendered drawing of the complete bird feeding table which shows all of the features that you have designed in (a)–(c). [20]



