

CANDIDATE  
NAME

CENTRE  
NUMBER

--	--	--	--	--	--

CANDIDATE  
NUMBER

--	--	--	--	--



**PHYSICAL SCIENCE**

**8780/04**

Paper 4 Advanced Practical Skills

**October/November 2014**

**1 hour 30 minutes**

Candidates answer on the Question Paper.

Additional Materials: As listed in the Confidential Instructions

**READ THESE INSTRUCTIONS FIRST**

Write your Centre number, candidate number and name on all the work you hand in.  
Give details of the practical session and laboratory where appropriate, in the boxes provided.  
Write in dark blue or black pen.  
You may use a pencil for any diagrams or graphs.  
Do not use staples, paper clips, glue or correction fluid.  
**DO NOT WRITE IN ANY BARCODES.**

Answer **both** questions.  
You will be allowed to work with the apparatus for a maximum of 45 minutes for each question.  
Electronic calculators may be used.  
You are advised to show all working in calculations.  
Use of a Data Booklet is unnecessary.

Qualitative Analysis Notes are printed on pages 13 and 14.

At the end of the examination, fasten all your work securely together.  
The number of marks is given in brackets [ ] at the end of each question or part question.

<b>Session</b>	
<b>Laboratory</b>	

<b>For Examiner's Use</b>	
<b>1</b>	
<b>2</b>	
<b>Total</b>	

This document consists of **13** printed pages and **3** blank pages.



- 1 In this experiment you will investigate the variation of current from a power supply with a variable resistor in the external circuit. You are provided with a selection of networks of eight different resistor values.

Each of the networks should be made up of a combination of resistors of identical resistance. However, it is suspected that **one of the resistors** has a different resistance.

- (a) Set up the circuit shown in Fig. 1.1.

Connect the  $5\Omega$  network between **X** and **Y**.

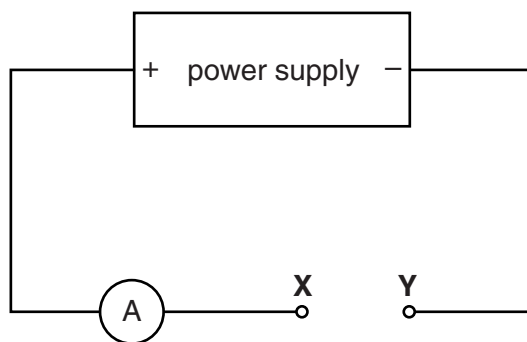
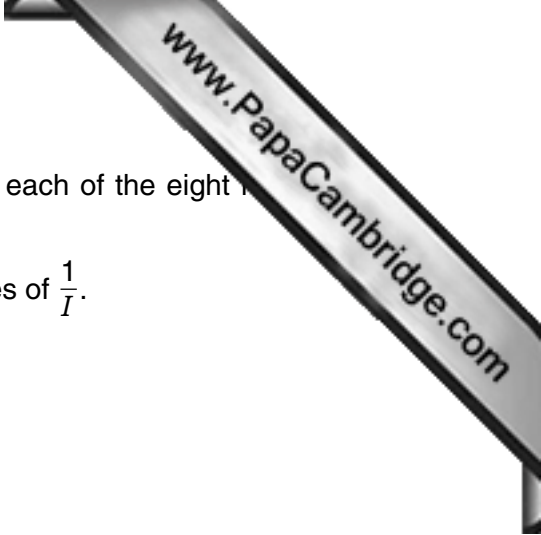

Fig. 1.1

Record the value of the current  $I$  through the ammeter. .... A



- (b) (i) Construct a suitable table to record the resistance  $R$  of each of the eight resistor networks and the corresponding current  $I$ .

You should include a column in which to record the values of  $\frac{1}{I}$ .

- (ii) Record, in the table, your first values of  $I$  and  $R$  from part (a).
- (iii) Change the resistor network and measure the new current  $I$ .  
Record the new values for  $R$  and  $I$  in your table.  
Repeat until all eight sets of readings are taken.

**Remove each resistor network from the circuit immediately after taking each reading.**

- (iv) Calculate and record the value of  $\frac{1}{I}$  for each measurement of  $I$ .

- (c) (i) On the grid provided, plot your values of  $\frac{1}{I}$  on the  $y$ -axis and  $R$  on the  $x$ -axis.  
Draw the straight line of best fit.

- (ii) Calculate the gradient of the graph.  
Show your working.

gradient = .....

- (iii) Use your graph to determine the value of  $I$  when  $R$  is zero.

$I$  ..... A

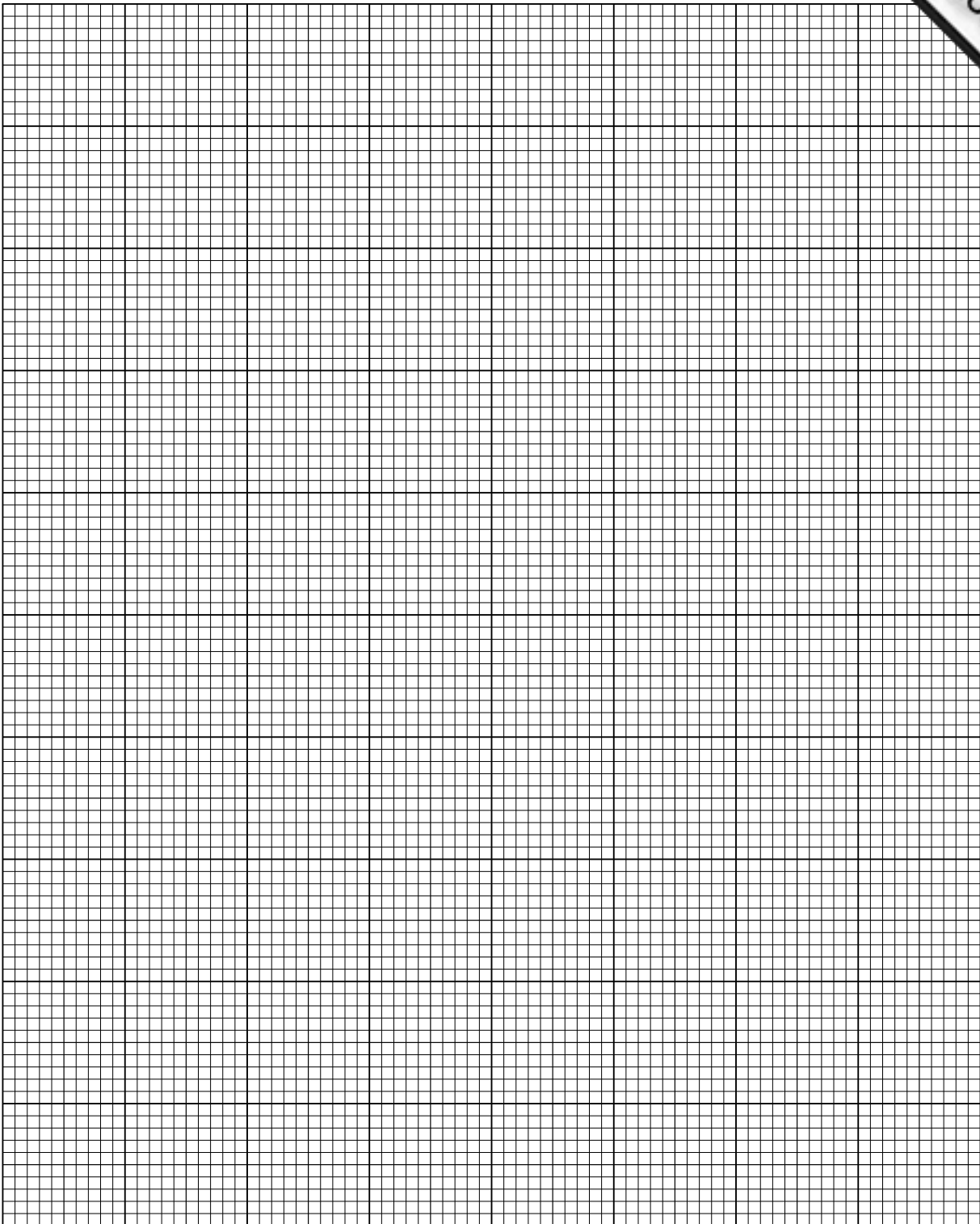
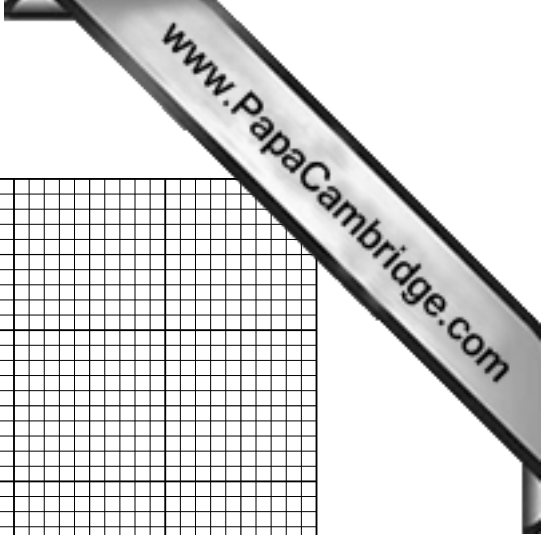

Question 1 continues on the next page

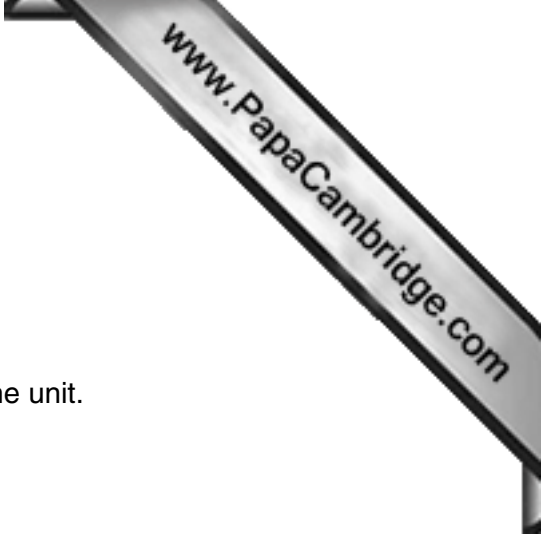
(d) The relationship between  $I$  and  $R$  is of the form

$$\frac{1}{I} = \frac{R}{E} + k$$

where  $E$  and  $k$  are constants.

Determine the value of the emf of the power supply  $E$ . Give the unit.

$E = \dots\dots\dots$  unit  $\dots\dots\dots$

(e) (i) From your graph, identify the network that contains a resistor of a different resistance from the others.

(ii) Test the resistors in this network to find the resistor which has a different resistance from the others.

Draw this network and label the resistor which has the different resistance with the letter **W**.

(iii) Determine the resistance of resistor **W**.  
Briefly explain how you obtained this value.

resistance =  $\dots\dots\dots \Omega$

explanation  $\dots\dots\dots$

$\dots\dots\dots$

$\dots\dots\dots$

[Total: 15]



**Question 2 starts on the next page**

2 You are provided with solution **P**, which contains iron ions, another cation and one anion.

- (a) Test portions of solution **P** for the presence of chloride and sulfate ions.  
Use no more than a total of 5 cm<sup>3</sup> for these two tests.

**Retain the remainder of solution P for further tests.**

Record the tests and your observations in the table below.

test	observations



(b) Carry out the tests described below.

Record all observations.

	test	observations
(i)	<p>Transfer 1 cm depth of solution <b>P</b> into a clean test-tube.</p> <p>Add 5 drops of aqueous sodium hydroxide.</p> <p>Add a further 1 cm depth of aqueous sodium hydroxide.</p> <p>Pour freshly boiled (very hot) water into a 500 cm<sup>3</sup> beaker until it is about one quarter full.</p> <p>Place the test-tube in this beaker for at least 2 minutes.</p> <p>Test for any gas evolved.</p>	
(ii)	<p>Transfer 1 cm depth of solution <b>P</b> into a clean test-tube.</p> <p>Add 1 cm depth of solution <b>Z</b>.</p>	

Retain the remainder of solution **P** for use in (b)(iii).

	test	observations
(iii)	<p>To the flask containing the remaining solution <b>P</b> add 20 cm<sup>3</sup> of hydrochloric acid.</p> <p>Then add 10 cm<sup>3</sup> of hydrogen peroxide.</p> <p>This is solution <b>Q</b>.</p>	
(iv)	<p>Transfer 1 cm depth of solution <b>Q</b> into a clean test-tube.</p> <p>Add 5 drops of aqueous sodium hydroxide.</p> <p>Add a further 1 cm depth of aqueous sodium hydroxide.</p>	
(v)	<p>Transfer 1 cm depth of solution <b>Q</b> into a clean test-tube.</p> <p>Add 1 cm depth of solution <b>Z</b> and leave to stand for 30 seconds.</p>	

Retain the remainder of solution **Q** for use in (b)(vi).

test	observations
<p><b>(vi)</b> To the flask containing the remaining solution <b>Q</b> add 3 pieces of granulated zinc.</p> <p>Empty the 500 cm<sup>3</sup> beaker and refill with freshly boiled (very hot) water until it is about one quarter full.</p> <p>Place the flask in this beaker for about 3 minutes.</p> <p><b>Do not test the gas evolved.</b></p> <p>The flask now contains solution <b>R</b>.</p>	
<p><b>(vii)</b> Transfer 1 cm depth of solution <b>R</b> into a clean test-tube.</p> <p>Add 5 drops of aqueous sodium hydroxide.</p> <p>Add a further 1 cm depth of aqueous sodium hydroxide.</p>	
<p><b>(viii)</b> Transfer 1 cm depth of solution <b>R</b> into a clean test-tube.</p> <p>Add 1 cm depth of solution <b>Z</b>.</p>	

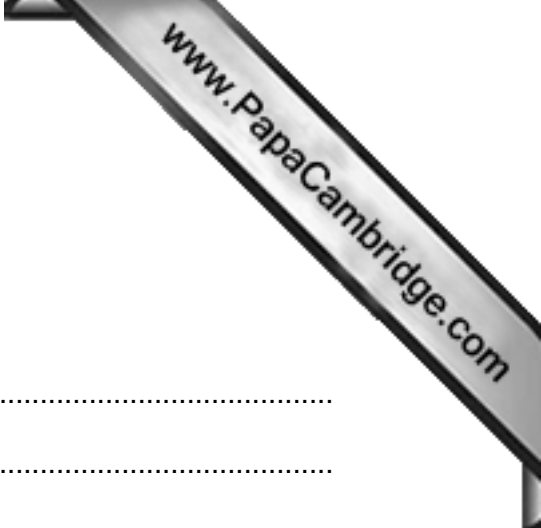
**(c) conclusions**

**(i)** Identify the three ions present in solution **P**.

In each case give evidence to support your conclusion.

.....  
.....  
.....  
.....  
.....  
.....

**(ii)** Suggest the role played by hydrogen peroxide in **(b)(iii)** and the role played by zinc in **(b)(vi)**.

In each case give evidence to support your suggestion.

role of hydrogen peroxide .....

evidence .....

.....  
.....

role of zinc .....

evidence .....

.....  
.....

**(iii)** State and explain what is happening to the iron ions in **(b)(i)**.

.....  
.....  
.....

--

[Total: 15]

## Qualitative Analysis Notes

Key: [ppt. = precipitate]

## 1 Reactions of aqueous cations

	<i>reaction with</i>	
	NaOH(aq)	NH <sub>3</sub> (aq)
aluminium, Al <sup>3+</sup> (aq)	white ppt. soluble in excess	white ppt. insoluble in excess
ammonium, NH <sub>4</sub> <sup>+</sup> (aq)	no ppt. ammonia produced on heating	—
barium, Ba <sup>2+</sup> (aq)	no ppt. (if reagents are pure)	no ppt.
calcium, Ca <sup>2+</sup> (aq)	white ppt. with high [Ca <sup>2+</sup> (aq)]	no ppt.
chromium(III), Cr <sup>3+</sup> (aq)	grey-green ppt. soluble in excess giving dark green solution	grey-green ppt. insoluble in excess
copper(II), Cu <sup>2+</sup> (aq)	pale blue ppt. insoluble in excess	blue ppt. soluble in excess giving dark blue solution
iron(II), Fe <sup>2+</sup> (aq)	green ppt. turning brown on contact with air insoluble in excess	green ppt. turning brown on contact with air insoluble in excess
iron(III), Fe <sup>3+</sup> (aq)	red-brown ppt. insoluble in excess	red-brown ppt. insoluble in excess
magnesium, Mg <sup>2+</sup> (aq)	white ppt. insoluble in excess	white ppt. insoluble in excess
manganese(II), Mn <sup>2+</sup> (aq)	off-white ppt. rapidly turning brown on contact with air insoluble in excess	off-white ppt. rapidly turning brown on contact with air insoluble in excess
zinc, Zn <sup>2+</sup> (aq)	white ppt. soluble in excess	white ppt. soluble in excess

## 2 Reactions of anions

<i>ion</i>	<i>reaction</i>
carbonate, $\text{CO}_3^{2-}$	$\text{CO}_2$ liberated by dilute acids
chloride, $\text{Cl}^-$ (aq)	gives white ppt. with $\text{Ag}^+$ (aq) (soluble in $\text{NH}_3$ (aq))
bromide, $\text{Br}^-$ (aq)	gives pale cream ppt. with $\text{Ag}^+$ (aq) (partially soluble in $\text{NH}_3$ (aq))
iodide, $\text{I}^-$ (aq)	gives yellow ppt. with $\text{Ag}^+$ (aq) (insoluble in $\text{NH}_3$ (aq))
nitrate, $\text{NO}_3^-$ (aq)	$\text{NH}_3$ liberated on heating with $\text{OH}^-$ (aq) and Al foil
nitrite, $\text{NO}_2^-$ (aq)	$\text{NH}_3$ liberated on heating with $\text{OH}^-$ (aq) and Al foil, $\text{NO}$ liberated by dilute acids (colourless $\text{NO} \rightarrow$ (pale) brown $\text{NO}_2$ in air)
sulfate, $\text{SO}_4^{2-}$ (aq)	gives white ppt. with $\text{Ba}^{2+}$ (aq) or with $\text{Pb}^{2+}$ (insoluble in excess dilute strong acid)
sulfite, $\text{SO}_3^{2-}$ (aq)	$\text{SO}_2$ liberated with dilute acids; gives white ppt. with $\text{Ba}^{2+}$ (aq) (soluble in excess dilute strong acid)

## 3 Tests for gases

<i>gas</i>	<i>test and test result</i>
ammonia, $\text{NH}_3$	turns damp red litmus paper blue
carbon dioxide, $\text{CO}_2$	gives a white ppt. with limewater (ppt. dissolves with excess $\text{CO}_2$ )
chlorine, $\text{Cl}_2$	bleaches damp litmus paper
hydrogen, $\text{H}_2$	“pops” with a lighted splint
oxygen, $\text{O}_2$	relights a glowing splint
sulfur dioxide, $\text{SO}_2$	turns acidified aqueous potassium manganate(VII) from purple to colourless



---

Permission to reproduce items where third-party owned material protected by copyright is included has been sought and cleared where possible. Every reasonable effort has been made by the publisher (UCLES) to trace copyright holders, but if any items requiring clearance have unwittingly been included, the publisher will be pleased to make amends at the earliest possible opportunity.

Cambridge International Examinations is part of the Cambridge Assessment Group. Cambridge Assessment is the brand name of University of Cambridge Local Examinations Syndicate (UCLES), which is itself a department of the University of Cambridge.