

**SECTION 1:** Answer **one** question from this section.

**Question 1**

A sketch of a card model shop is shown on the right. The model is to be used to show a design for a gift shop called 'ALL WRAPPED UP'.

- (a) In the space below, accurately draw **three** full size orthographic views of the model shop. Do **not** include the shop sign. [12]
- (b) In the box provided, draw the correct symbol to match the orthographic projection used. [4]

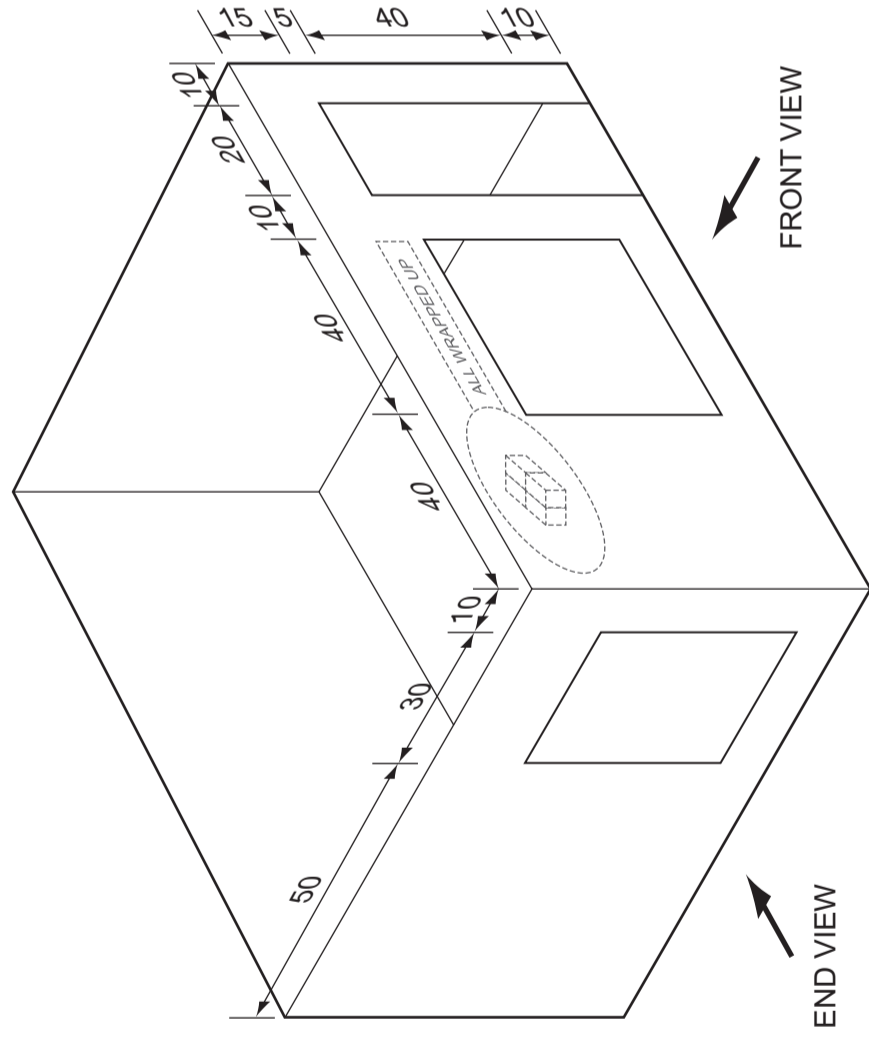

A sketch of the proposed name sign for the shop is shown on the right. The sign is made from a number of geometrical shapes.

- (c) Use instruments to complete the 1:20 scale drawing of the name sign below. [7]

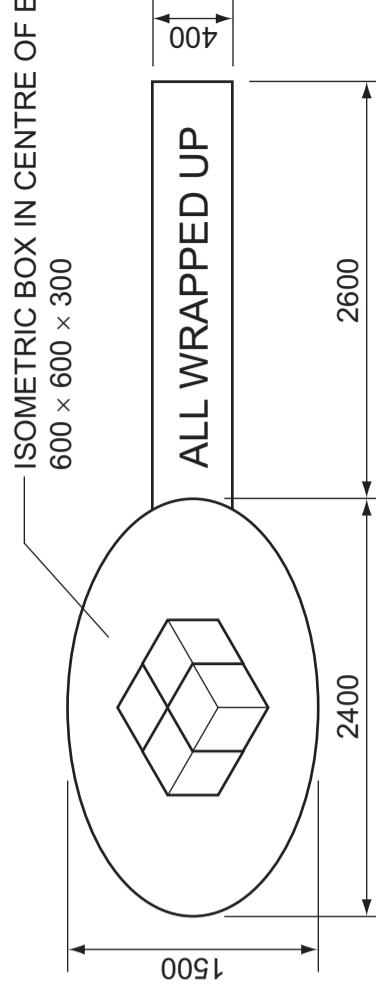

**ALL WRAPPED UP**

- (d) Complete the oblique drawing of the model of the shop on the right by adding:

- (i) the missing outline;
- (ii) the windows and door;
- (iii) the shop sign.

Estimate any dimensions not given. [7]

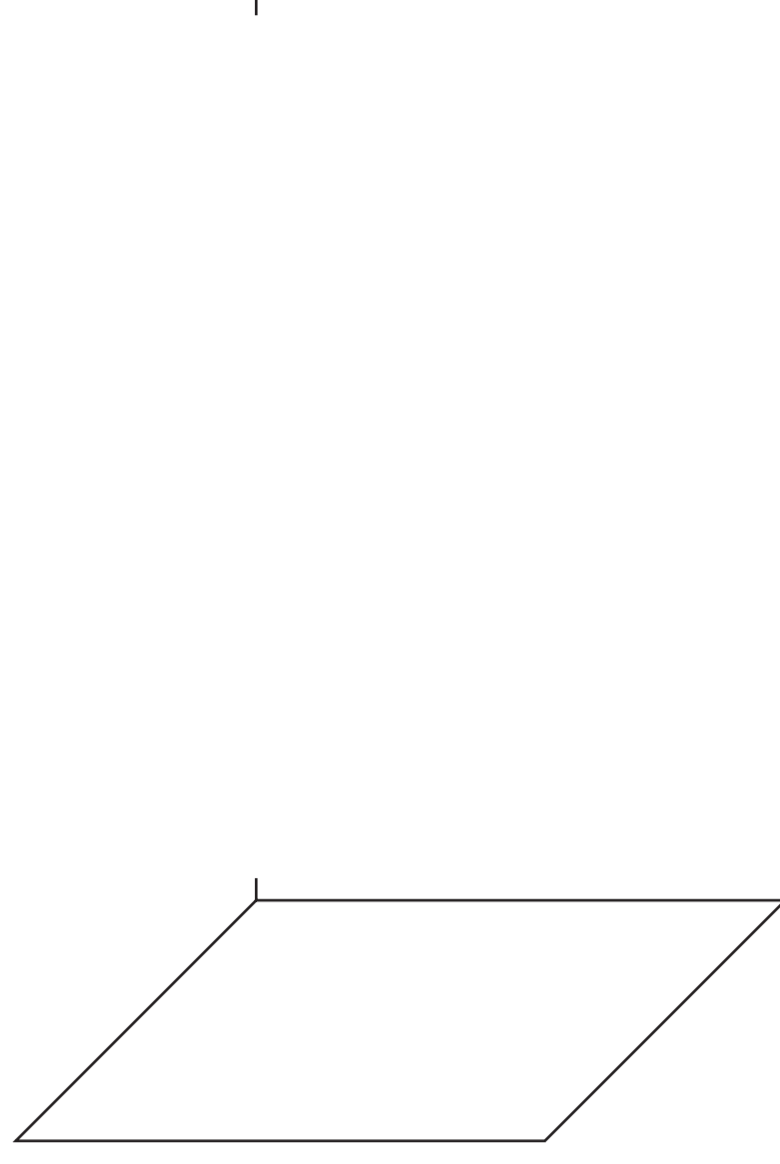

A colour scheme is required for the front of the shop based upon 'bright and bold' colours of the type used in wrapping paper.

- (e) On the outline of the shop front, show an idea for a colour scheme. [4]

FULL SIZE

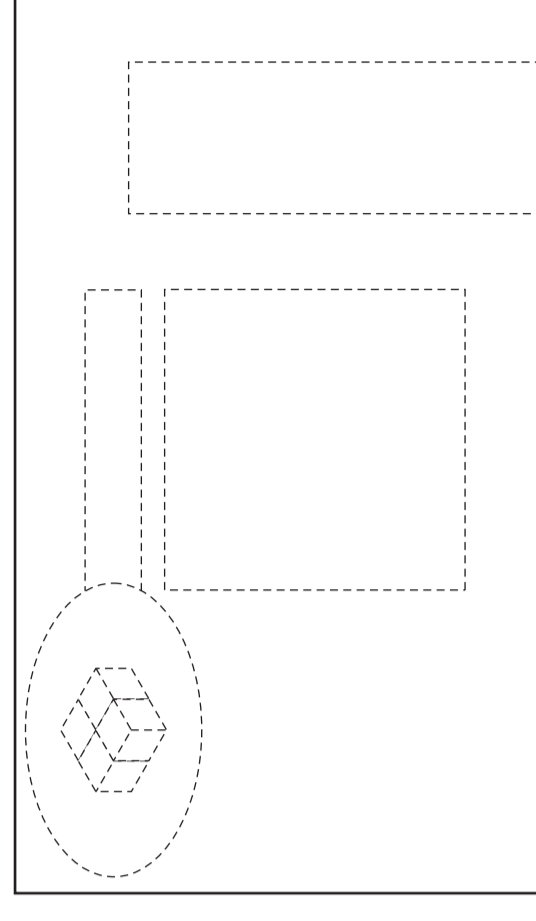

Outline of shop front

SCALE 1:1

PROJECTION SYMBOL

[Turn over



UNIVERSITY OF CAMBRIDGE INTERNATIONAL EXAMINATIONS  
General Certificate of Education Ordinary Level

7048/01

October/November 2009

2 hours 30 minutes

plus 15 minutes reading time

IB09\_11\_7048\_01/3RP

No Additional Materials are required

© UCLES 2009

**SHEET 1 OF 2 (SECTION 1)**

Print your surname, other names, Centre number and candidate number in the spaces provided.

Answer **one** question only from Section 1 (Questions 1 and 2).

Answer **two** questions only from Section 2 (Questions 3 to 6).

Answer the questions in the spaces provided.

All construction and projection lines must be clearly shown.

All dimensions are in millimetres unless otherwise stated.

The number of marks is given in brackets [ ] at the end of each question or part question.

DO **NOT** WRITE IN ANY BARCODES.

Candidate Surname .....  
Other Names .....  
Centre Number .....  
Candidate Number .....

Examiner's use only

**Question 2**

Orthographic views of a shop counter are shown on the right. The counter is used by shop assistants when serving customers. The counter is made from 20 mm thick chipboard.

(a) Draw an isometric view of the counter to a scale of 1:10 from the given start point **A**. Estimate any dimensions not given. [15]

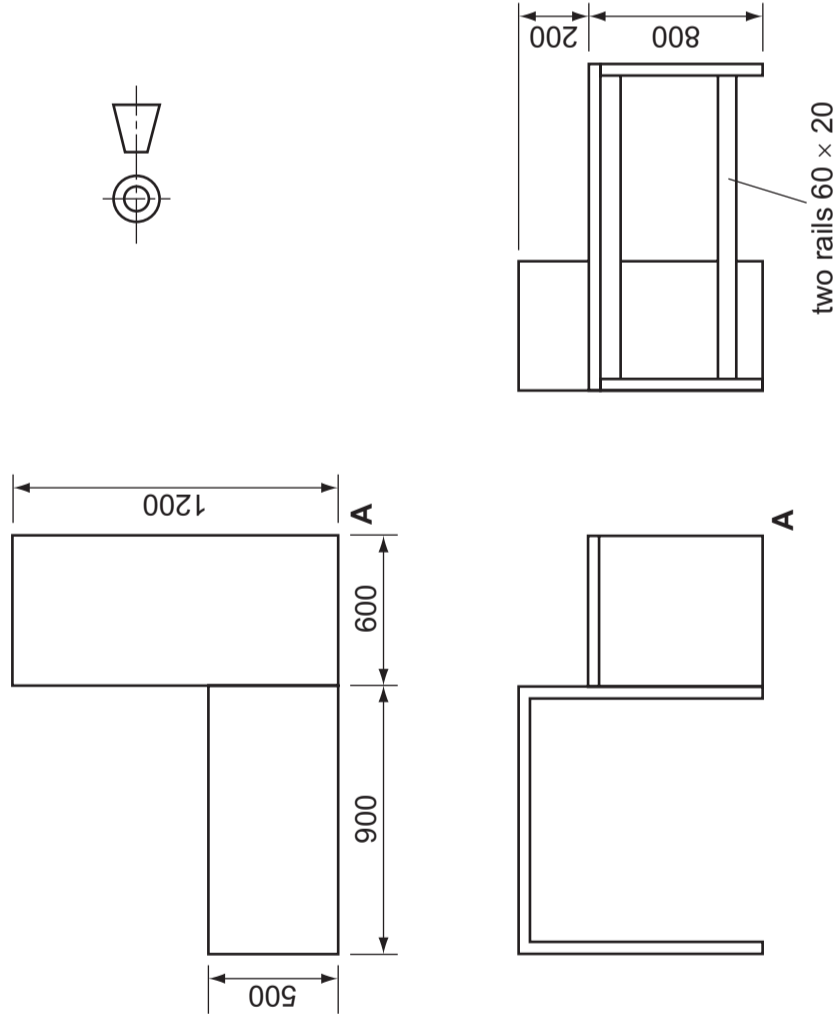

(b) The counter is delivered to the shop in a flat-pack form and then fastened together with dowels and glue. An exploded sketch of the dowel joint is shown below. Complete the sectional view of the dowel joint shown on the right. [5]

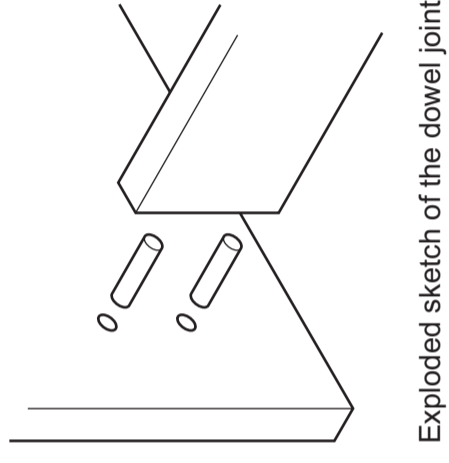

Exploded sketch of the dowel joint

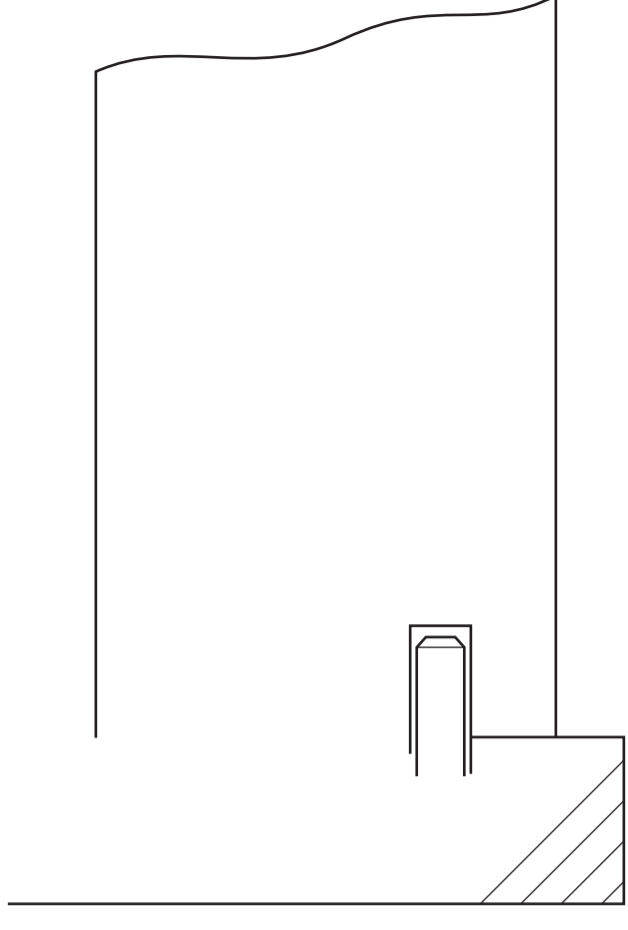

Sectional view of the dowel joint

(c) An instruction leaflet is used to show the steps required to make a dowel joint. Complete the instruction leaflet by adding sketches to the boxes below. [8]

STEP 1	STEP 2	STEP 3	STEP 4	STEP 5
Squeeze a small amount of glue into the holes in parts <b>A</b> and <b>B</b> .	Use a mallet to tap the dowel into the hole in part <b>B</b> .	Locate the dowel into the hole in part <b>A</b> and push together.	Wipe off the excess glue.	Apply pressure to the joint for 24 hours.

(d) The illustrations below are to be used to show the different finishes available for the shop counter. Complete the illustrations by rendering to show each finish. [6]

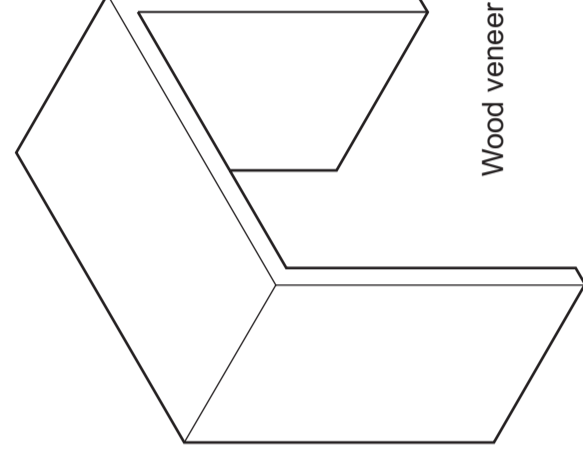

Wood veneer

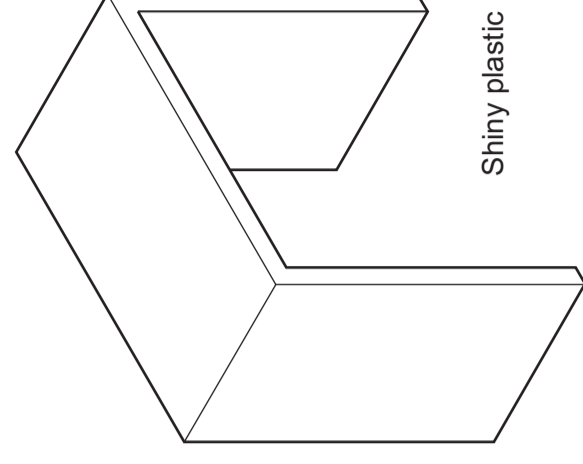

Shiny plastic

**SECTION 2:** Answer two questions from this section.

**Question 3**

A sketch of a card package for sweets is shown below. The package is filled with a selection of sweets that have been chosen by the customer.

(a) Complete the full size drawing of the development (net) of the package on the given start lines. Clearly show all fold lines, glue tabs and fold in flaps. [16]

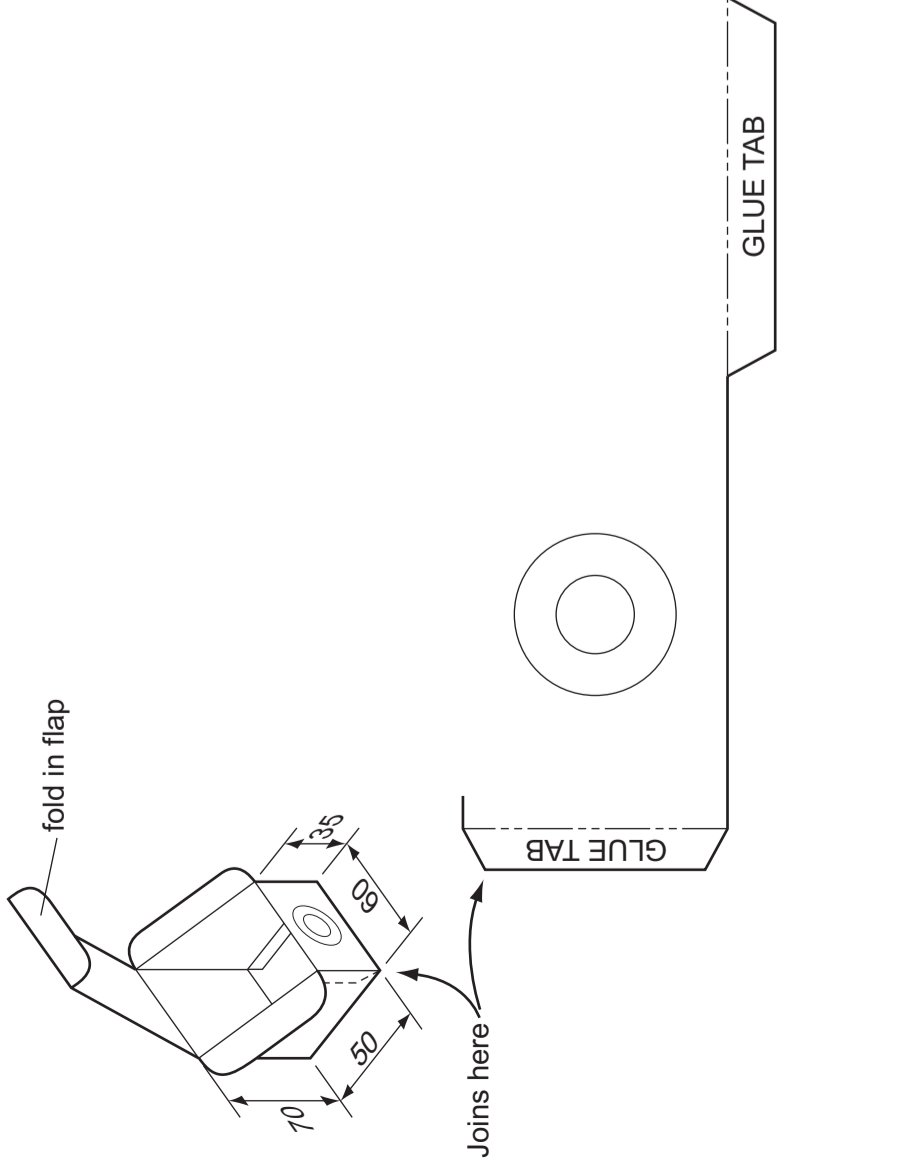

The card package for sweets is to be displayed on an acrylic stand. The display stand must:

- stand on the counter;
- hold one package of sweets;
- show that a range of sweets is available;
- show that the customer is able to choose the sweets.

(b) In the space below, use sketches and notes to show an idea for the acrylic display stand. [7]

(c) In the space below, draw a three dimensional view of the display stand designed in (b). Use colour rendering to show that the stand is made from acrylic. [10]

**Question 4**

The shop uses a range of different shaped card packages for gifts. These packages are stacked in piles on shelves behind the counter.

(a) Orthographic views of four piles of boxes are shown on the right. Complete the drawings by adding the missing three dimensional (3D) sketches. [12]

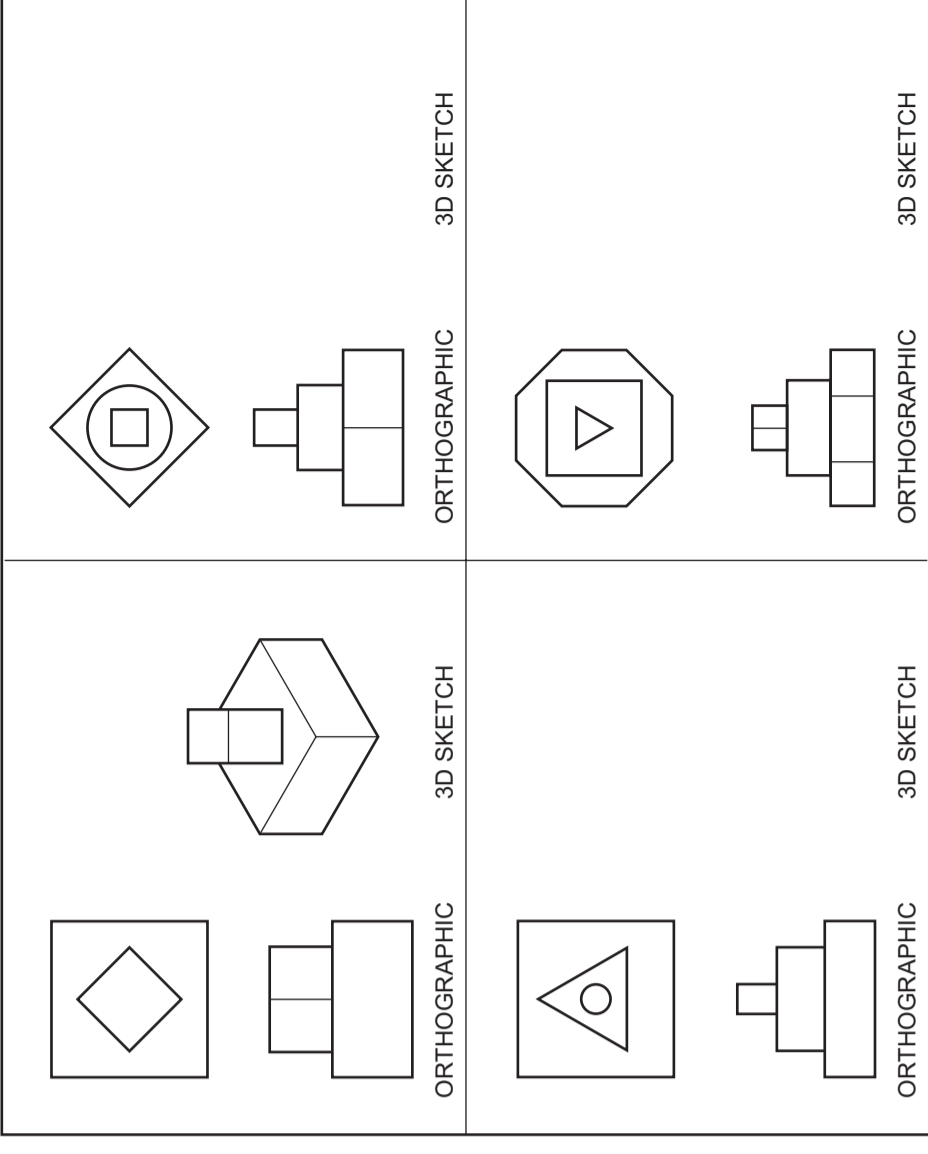

The shop has designed a series of labels to be attached to gifts. The labels have a shape and a letter printed on the front. An example of a label is shown below.

(b) Complete the drawings of the last three labels shown on the right. Add the missing shapes and letters to the same size and format as the completed label. [8]

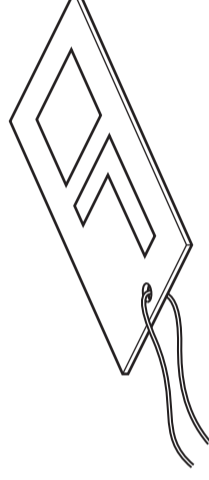

LABEL

COMPLETED LABEL

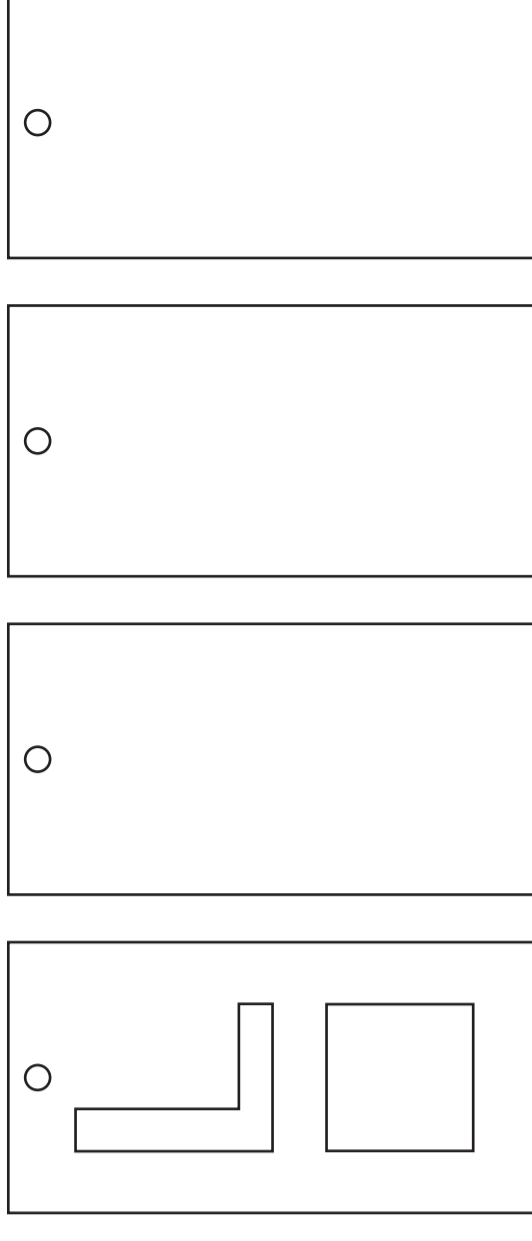

A manufacturer has decided to develop a new series of labels that are folded and have a letter that 'pops up' when the label is opened.

(c) In the space below, use sketches and notes to show an idea for a mechanism that will make a letter 'L' 'pop up' when the label is opened. [5]

(d) In the space below, draw a three dimensional view of the 'pop up' label designed in (c). Show the label in the open position with the 'pop up' 'L' clearly visible. Add colour to enhance the appearance of your drawing. [8]

**Question 5**

Orthographic sketches of an acrylic stand to display a watch are shown on the right. The stand is made from two parts, labelled as base and top.

(a) In the space below, complete the drawing of the development (net) of the **base** of the acrylic display stand to a scale of 1:2. Point **A** has been given as a starting point. [13]

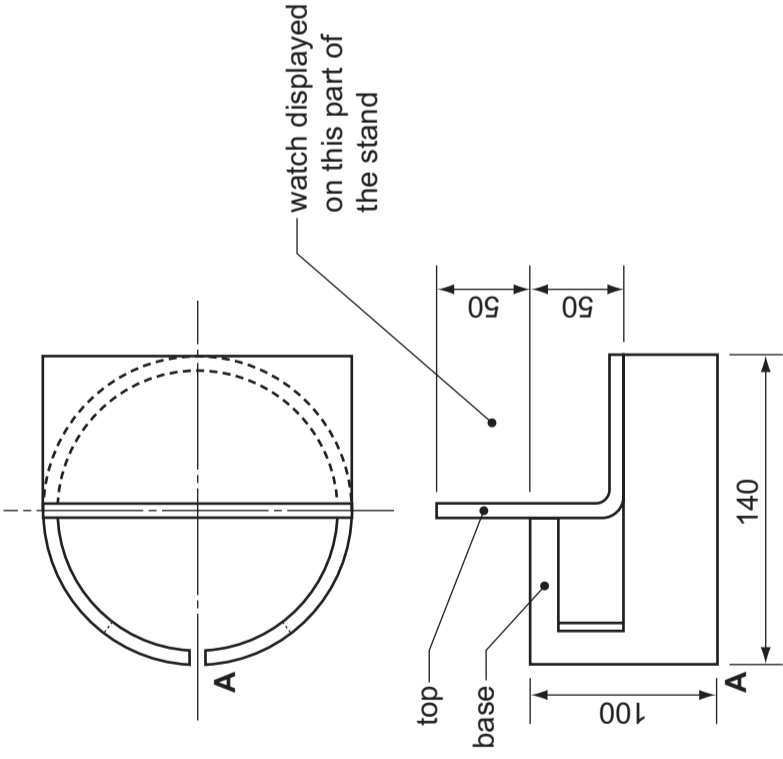
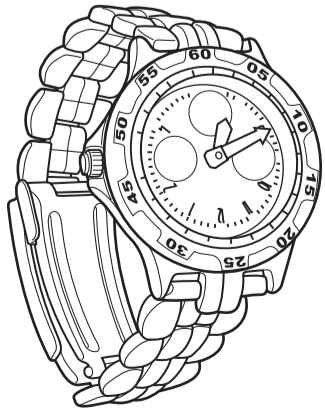

(b) The top of the stand is made from a 170 mm × 140 mm rectangle of acrylic folded at 90 degrees. Testing has shown that the top does not hold the watch in position. In the space on the right, draw a design that will hold the watch in position on the top of the stand. [6]

(c) A self adhesive label is to be added to the front of the base of the display stand to show the name of the watch. In the space on the right, use sketches and notes to show your ideas for a label based upon the theme 'Diving'. [6]

(d) In the space on the right, sketch a pictorial view of the modified display stand and the label. Add colour to enhance the appearance of your sketch. Do **not** show the watch. [8]

**Question 6**

The income for the shop over a one week period is shown in the table below.

	Monday	Tuesday	Wednesday	Thursday	Friday	Saturday
Income	\$300	\$550	\$400	\$250	\$900	\$1200

(a) Draw a pie chart on the centre lines given to show the distribution of the income for the week. Use colour and a key to enhance your illustration. [8]

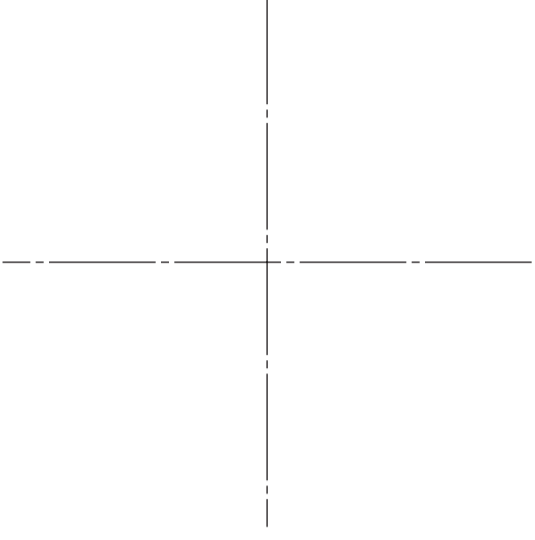

Sales figures for the last six months of trading are shown in the table below.

	June	July	August	Sept	Oct	Nov
Sales	\$12 000	\$9 000	\$7 000	\$10 000	\$10 000	\$8 500

(b) In the space on the right, produce a bar chart to show the sales figures for the last six months of trading. Use colour and labels to enhance your illustration. [8]

The owner of the shop has decided to produce a flow chart to show staff how to 'cash up' at the end of the day. The steps are:

- 1 Sort coins
- 2 Count coins
- 3 Check coin totals
- 4 Put money in bags
- 5 Complete form
- 6 Deposit at bank

(c) Use the symbols given to complete the flow chart below to show the stages in 'cashing up'. [8]



(d) The sketch below shows the symbol that is used to identify cash deposit machines. Complete the drawing of the symbol on the given start lines. [9]

