

CANDIDATE  
NAME

--

CENTRE  
NUMBER

--	--	--	--	--

CANDIDATE  
NUMBER

--	--	--	--



**MATHEMATICS (SYLLABUS D)**

**4024/22**

Paper 2

**October/November 2015**

**2 hours 30 minutes**

Candidates answer on the Question Paper.

Additional Materials:      Geometrical instruments  
   Electronic calculator

**READ THESE INSTRUCTIONS FIRST**

Write your Centre number, candidate number and name on all the work you hand in.

Write in dark blue or black pen.

You may use a pencil for any diagrams or graphs.

Do not use staples, paper clips, glue or correction fluid.

**DO NOT WRITE IN ANY BARCODES.**

**Section A**

Answer **all** questions.

**Section B**

Answer any **four** questions.

If working is needed for any question it must be shown in the space below that question.

Omission of essential working will result in loss of marks.

You are expected to use an electronic calculator to evaluate explicit numerical expressions.

If the degree of accuracy is not specified in the question, and if the answer is not exact, give the answer to three significant figures. Give answers in degrees to one decimal place.

For  $\pi$ , use either your calculator value or 3.142, unless the question requires the answer in terms of  $\pi$ .

The number of marks is given in brackets [ ] at the end of each question or part question.

The total of the marks for this paper is 100.

This document consists of **24** printed pages.

**Section A** [52 marks]Answer **all** questions in this section**1 (a)** Fatima and Mohammed buy new bikes.**(i)** Fatima buys a city bike costing \$360.  
She pays 60% of the cost then pays \$15 per month for 12 months.**(a)** How much does Fatima pay altogether?*Answer* \$..... [2]**(b)** Express this amount as a percentage of the original cost.*Answer* ..... % [1]

- (ii) Mohammed pays \$569.80 for a mountain bike in a sale.  
The original price had been reduced by 26%.

Calculate the original price of the mountain bike.

*Answer* \$..... [2]

- (b) The rate of exchange between pounds (£) and dollars is  $\text{£}1 = \$1.87$  .  
The rate of exchange between pounds (£) and euros (€) is  $\text{£}1 = \text{€}x$  .  
Rose changed \$850 and received €550 .

Calculate  $x$ .

*Answer*  $x =$  ..... [3]

---

- 2  $A$  is the point  $(8, 7)$ ,  $B$  is the point  $(-2, 11)$  and  $C$  is the point  $(1, 7)$ .

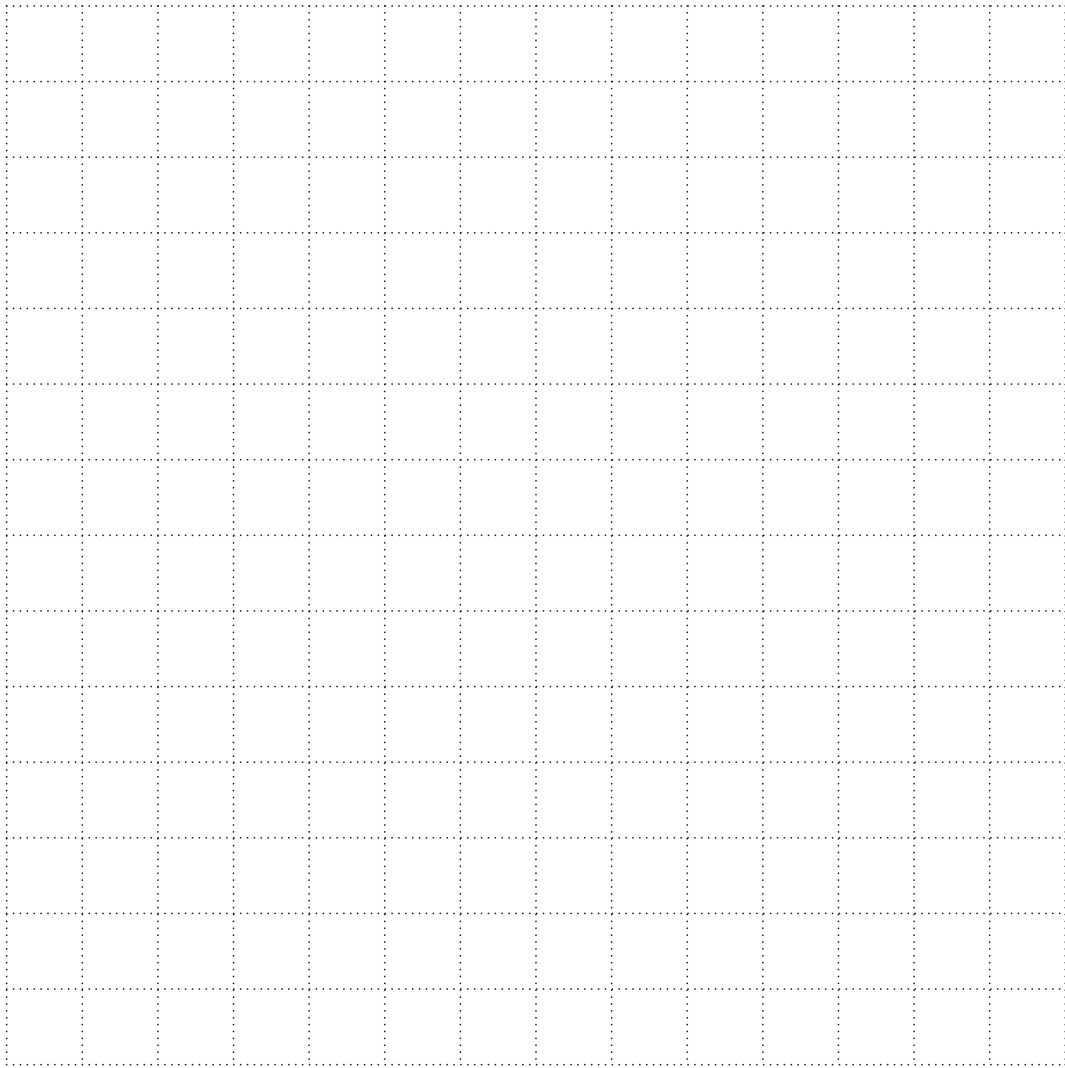

- (a) Calculate the area of triangle  $ABC$ .

*Answer* ..... units<sup>2</sup> [2]

(b) Calculate the length of  $AB$ .

*Answer* ..... units [2]

(c) Calculate the perimeter of triangle  $ABC$ .

*Answer* ..... units [2]

(d) Calculate  $\hat{BAC}$ .

*Answer* ..... [2]

---

3 (a)

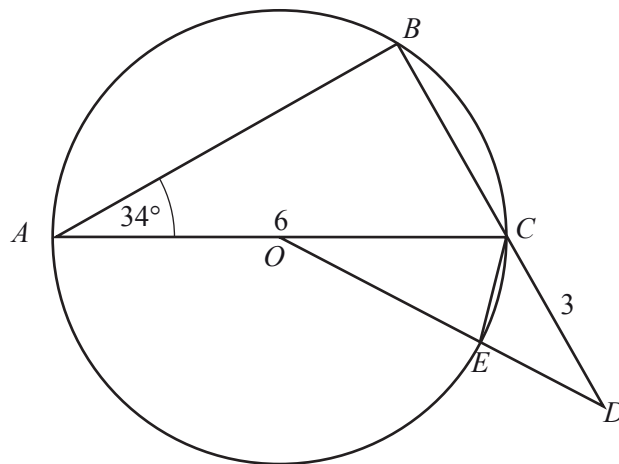

$AC$  is a diameter of the circle, centre  $O$ .  
 $BCD$  and  $OED$  are straight lines.  
 $AC = 6$  cm and  $CD = 3$  cm.  
 $\hat{BAC} = 34^\circ$ .

(i) Explain why  $\hat{BCA} = 56^\circ$ .

[1]

(ii) Find  $\hat{COD}$ .

Answer ..... [2]

(iii) Find  $\hat{OCE}$ .

Answer ..... [1]

(b)

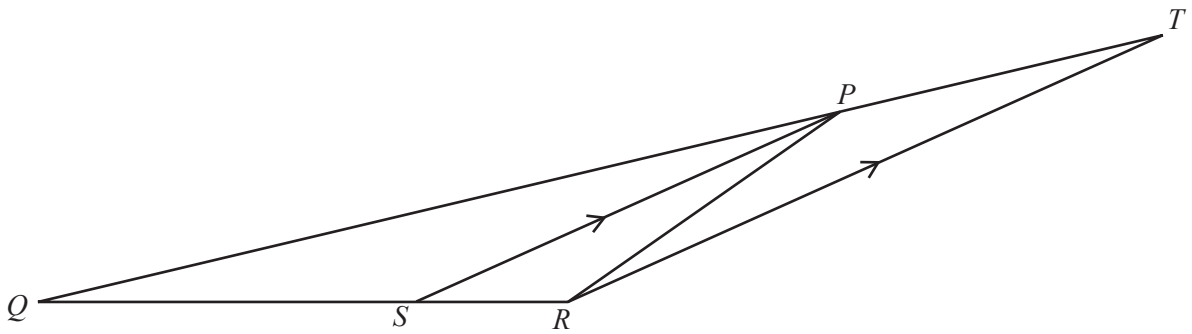

In the diagram,  $PS$  is the bisector of  $\widehat{QPR}$ .  
 $QPT$  and  $QSR$  are straight lines.  
 $RT$  is parallel to  $SP$ .

(i) Explain why  $PT = PR$ .

[2]

(ii) This diagram shows part of the above diagram.  
 $PQ = 12$  cm,  $PR = 5$  cm and  $QR = 8.5$  cm.

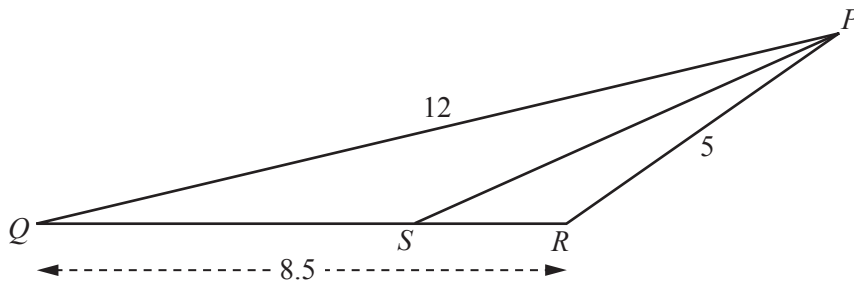

It is given that  $\frac{PQ}{PR} = \frac{QS}{SR}$ .

Find  $SR$ .

Answer ..... cm [3]

4 [The volume of a sphere is  $\frac{4}{3}\pi r^3$ ]

(a)

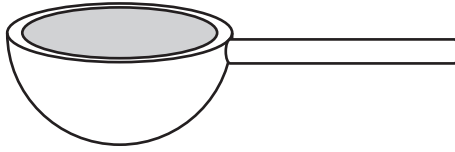

A spoon used for measuring in cookery consists of a hemispherical bowl and a handle. The internal volume of the hemispherical bowl is  $20\text{ cm}^3$ . The handle is of length 5 cm.

(i) Find the internal radius of the hemispherical bowl.

*Answer* ..... cm [2]

(ii) The hemispherical bowl of a geometrically similar spoon has an internal volume of  $50\text{ cm}^3$ .

Find the length of its handle.

*Answer* ..... cm [2]



(b) [The surface area of a sphere is  $4\pi r^2$ ]

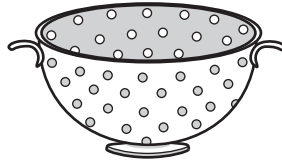

An open hemisphere of radius 5.5 cm is used to make a metal kitchen strainer.  
50 holes are cut out of the curved surface.

Assume that the piece of metal removed to make each hole is a circle of radius 1.5 mm.

Calculate the external surface area that remains.

*Answer* ..... cm<sup>2</sup> [3]

---

5

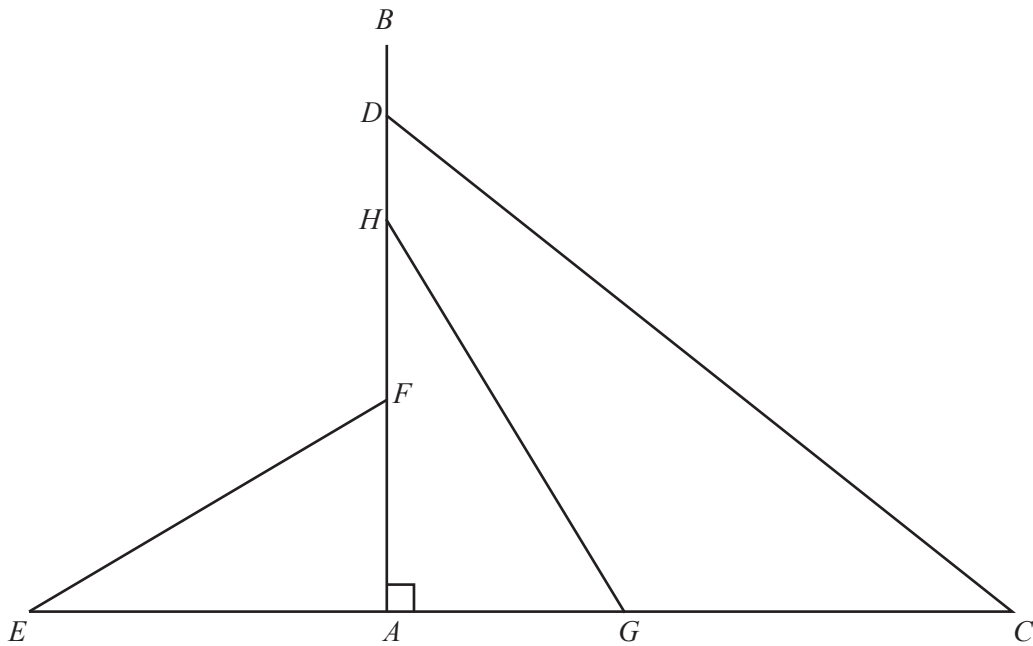

The diagram shows a vertical radio mast,  $AB$ .

Three of the wires that hold the mast in place are attached to it at  $F$ ,  $H$  and  $D$ .

The base  $A$  of the mast, and the ends  $E$ ,  $G$  and  $C$  of the wires are in a straight line on horizontal ground.

- (a) The wire  $CD$  has length 65 m.  
It is attached to the mast at  $D$  where  $AD = 40$  m.

Calculate  $AC$ .

*Answer* ..... m [2]

(b) The wire  $EF$  makes an angle of  $25^\circ$  with the horizontal and is of length 30 m.

Calculate  $AF$ .

*Answer* ..... m [2]

(c)  $AH = 35$  m.

The wire  $HG$  makes an angle of  $30^\circ$  with the mast  $AB$ .

Calculate  $HG$ .

*Answer* ..... m [3]

---

6 (a) (i) Solve the equation  $\left(x + \frac{7}{2}\right) = \pm \frac{\sqrt{5}}{2}$ .

Give both answers correct to 2 decimal places.

*Answer*  $x = \dots\dots\dots$  or  $\dots\dots\dots$  [2]

(ii) The solutions of  $\left(x + \frac{7}{2}\right) = \pm \frac{\sqrt{5}}{2}$  are also the solutions of  $x^2 + Bx + C = 0$ ,  
where  $B$  and  $C$  are integers.

Find  $B$  and  $C$ .

*Answer*  $B = \dots\dots\dots C = \dots\dots\dots$  [3]

(b) Solve the inequality  $7 - 3x > 13$ .

*Answer*  $x \dots\dots\dots$  [2]

(c) Factorise  $6x - 3yt + 18y - xt$ .

*Answer* ..... [2]

(d) Solve these simultaneous equations.

$$\begin{aligned}3a + 4b &= -13 \\5a + 6b &= -11\end{aligned}$$

*Answer*  $a =$  .....

$b =$  ..... [4]

---

## Section B [48 marks]

Answer **four** questions in this section.

Each question in this section carries 12 marks.

7

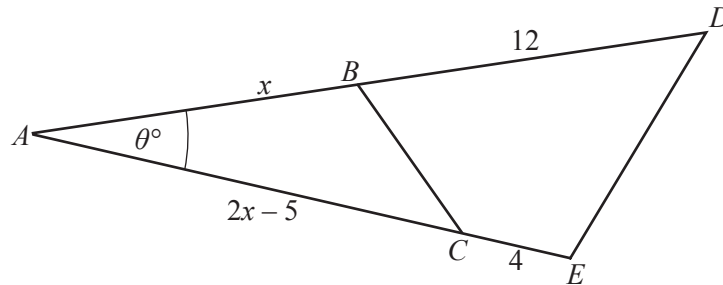

$ABD$  and  $ACE$  are straight lines.

$BD = 12$  cm and  $CE = 4$  cm.

$AB = x$  cm and  $AC = (2x - 5)$  cm.

Angle  $BAC = \theta^\circ$ .

- (a) Show that  $\frac{\text{area of triangle } ABC}{\text{area of triangle } ADE} = \frac{AB \times AC}{AD \times AE}$ .

[2]

- (b) It is given that  $\frac{\text{area of triangle } ABC}{\text{area of triangle } ADE} = \frac{1}{3}$ .

Using the result from part (a), form an equation in  $x$  and show that it simplifies to  $2x^2 - 19x + 6 = 0$ .

[3]

- (c) (i) Solve the equation  $2x^2 - 19x + 6 = 0$ , giving your answers correct to 2 decimal places.

*Answer*  $x = \dots\dots\dots$  or  $\dots\dots\dots$  [3]

- (ii) State, with a reason, which of these solutions does **not** apply to triangle  $ABC$ .

*Answer*  $\dots\dots\dots$  [1]

- (d) Given that  $\theta = 25$ , calculate  $BC$ .

*Answer*  $\dots\dots\dots$  cm [3]

---

8 (a)  $OAB$  is a sector of a circle, centre  $O$ , radius 6 cm.

$\widehat{AOB} = 25^\circ$ .

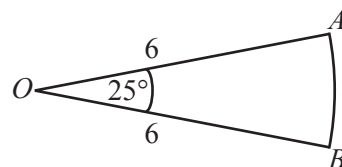

(i) Calculate the length of the arc  $AB$ .

Answer ..... cm [2]

(ii) Calculate the area of the sector  $OAB$ .

Answer .....  $\text{cm}^2$  [2]

(b) The sector  $OAB$  from part (a) is the cross-section of a slice of cheese.

The slice has a height of 5 cm.

(i) Calculate the volume of this slice of cheese.

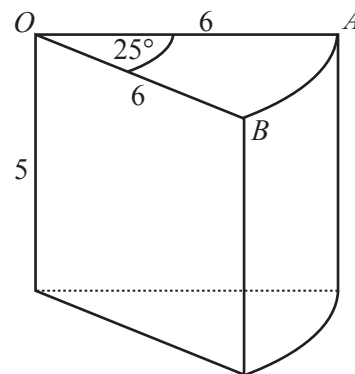

Answer .....  $\text{cm}^3$  [1]

(ii) Calculate the total surface area of this slice of cheese.

Answer .....  $\text{cm}^2$  [3]



- (iii) Another  $25^\circ$  slice of cheese has 3 times the height and twice the radius.

Calculate its volume.

Answer .....  $\text{cm}^3$  [2]

- (c) A dairy produces cylindrical cheeses, each with a volume of  $800 \text{ cm}^3$ .

The height  $h$  cm and the radius  $r$  cm can vary.

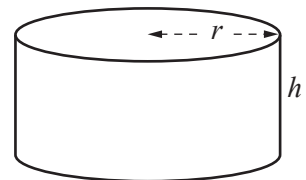

- (i) Express  $h$  in terms of  $r$ .

Answer ..... [1]

- (ii) What happens to the height if the radius is doubled?

Answer..... [1]

9 The distance,  $d$  metres, of a moving object from an observer after  $t$  minutes is given by

$$d = t^2 + \frac{48}{t} - 20.$$

- (a) Some values of  $t$  and  $d$  are given in the table.  
The values of  $d$  are given to the nearest whole number where appropriate.

$t$	1	1.5	2	2.5	3	3.5	4	4.5	5	6	7
$d$	29	14	8	5	5	6	8	11	15	24	

Complete the table. [1]

- (b) On the grid, plot the points given in the table and join them with a smooth curve.

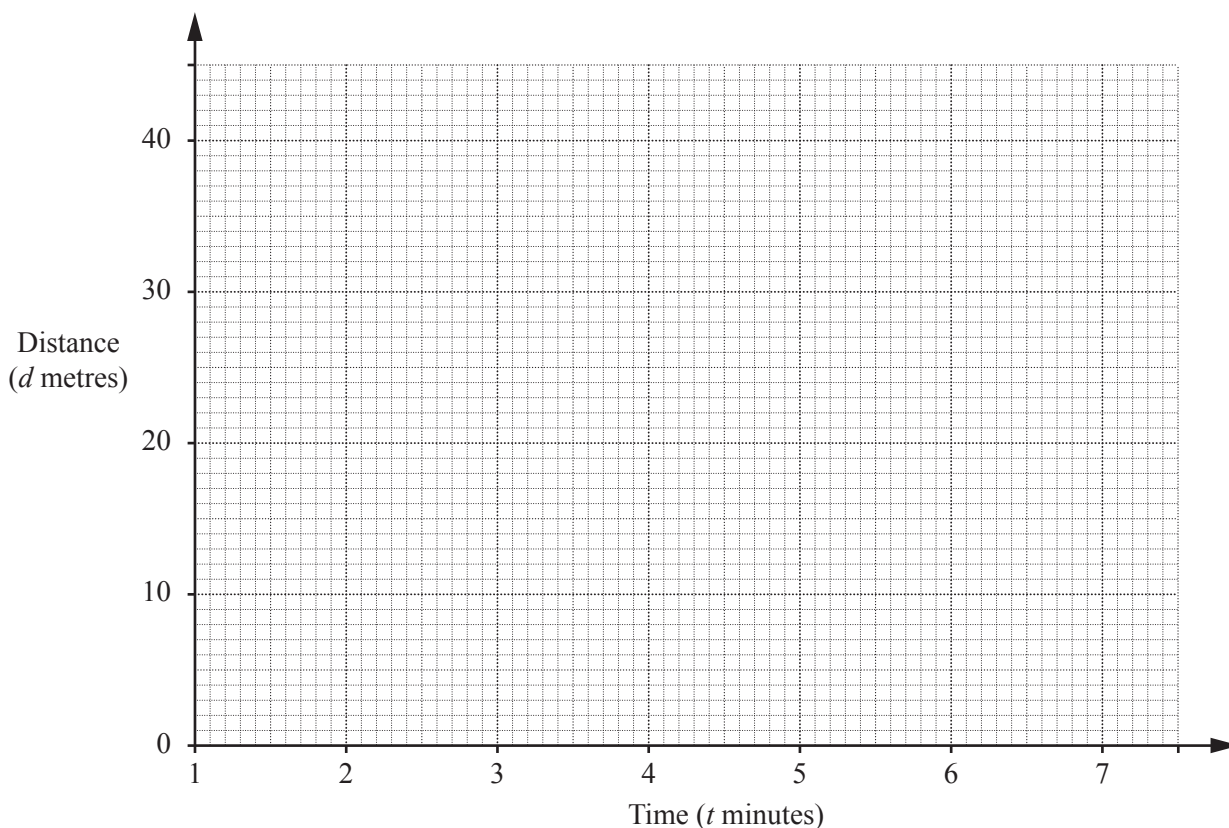

[2]

- (c) (i) By drawing a tangent, calculate the gradient of the curve when  $t = 4$ .

*Answer* ..... [2]

- (ii) Explain what this gradient represents.

*Answer* ..... [1]

(d) For how long is the object less than 10 metres from the observer?

*Answer* ..... minutes [2]

(e) (i) Using your graph, write down the two values of  $t$  when the object is 12 metres from the observer.

For each value of  $t$ , state whether the object is moving towards or away from the observer.

*Answer* When  $t = \dots\dots\dots$ , the object is moving ..... the observer.

When  $t = \dots\dots\dots$ , the object is moving ..... the observer. [2]

(ii) Write down the equation that gives the values of  $t$  when the object is 12 metres from the observer.

*Answer* ..... [1]

(iii) This equation is equivalent to  $t^3 + At + 48 = 0$ .

Find  $A$ .

*Answer*  $A = \dots\dots\dots$  [1]

---

- 10 The length of time taken by 80 drivers to complete a particular journey is summarised in the table below.

Time ( $t$ minutes)	$60 < t \leq 80$	$80 < t \leq 90$	$90 < t \leq 95$	$95 < t \leq 100$	$100 < t \leq 110$	$110 < t \leq 130$
Number of drivers	4	10	14	20	24	8

- (a) Using a scale of 2 cm to represent 10 minutes, draw a horizontal axis for times from 60 minutes to 130 minutes.

Choose a suitable scale for the vertical axis and draw a histogram to represent this information.

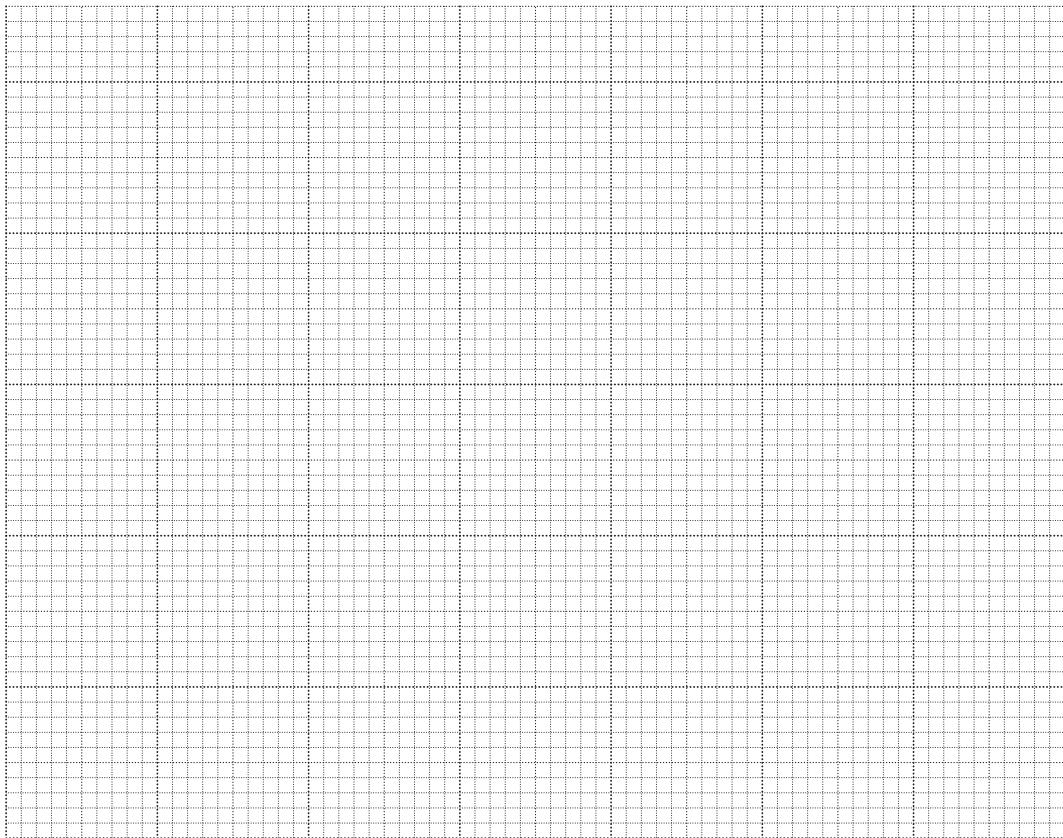

[3]

(b) In which of the intervals does the median time lie?

*Answer* ..... [1]

(c) Calculate an estimate of the mean time taken to complete the journey.

*Answer* ..... minutes [3]

(d) One driver is chosen at random.

Calculate the probability that this driver took 95 minutes or less for the journey.

*Answer* ..... [1]

(e) Two of the 80 drivers are chosen at random.

(i) Calculate the probability that both took more than 100 minutes for the journey.

*Answer* ..... [2]

(ii) Calculate the probability that one took 80 minutes or less and the other took more than 110 minutes.

*Answer* ..... [2]

---

11 (a)

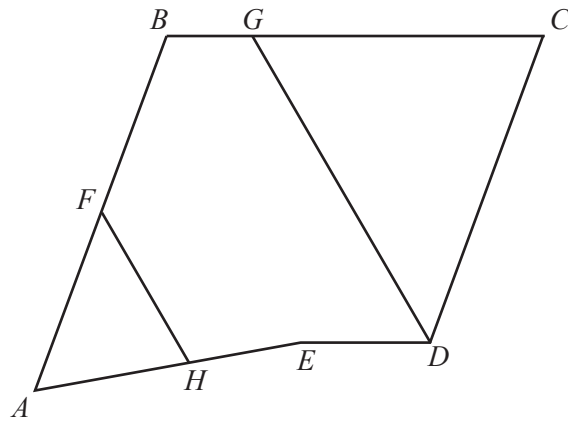

$ABCDE$  is a pentagon.  
 $AFB$ ,  $AHE$  and  $BGC$  are straight lines.

(i)  $\vec{AE} = \begin{pmatrix} 6 \\ 1 \end{pmatrix}$ .

Calculate  $|\vec{AE}|$ .

Answer ..... units [1]

(ii)  $H$  is the midpoint of  $AE$ , and  $\vec{FH} = \begin{pmatrix} 2 \\ -3.5 \end{pmatrix}$ .

Find  $\vec{AF}$ .

Answer ..... [2]

(iii)  $G$  divides  $BC$  in the ratio  $1 : 2$ .

$$\overrightarrow{BG} = \begin{pmatrix} 2.5 \\ 0 \end{pmatrix} \text{ and } \overrightarrow{CD} = \begin{pmatrix} -1 \\ -7 \end{pmatrix}.$$

(a) Find  $\overrightarrow{GD}$ .

*Answer* ..... [1]

(b) Explain why  $GD$  is parallel to  $FH$ .

[1]

(iv)  $B$  is the point  $(3, 10)$ .

Find the coordinates of  $D$ .

*Answer* (....., .....) [1]

**Question 11(b) is printed on the next page**

(b)

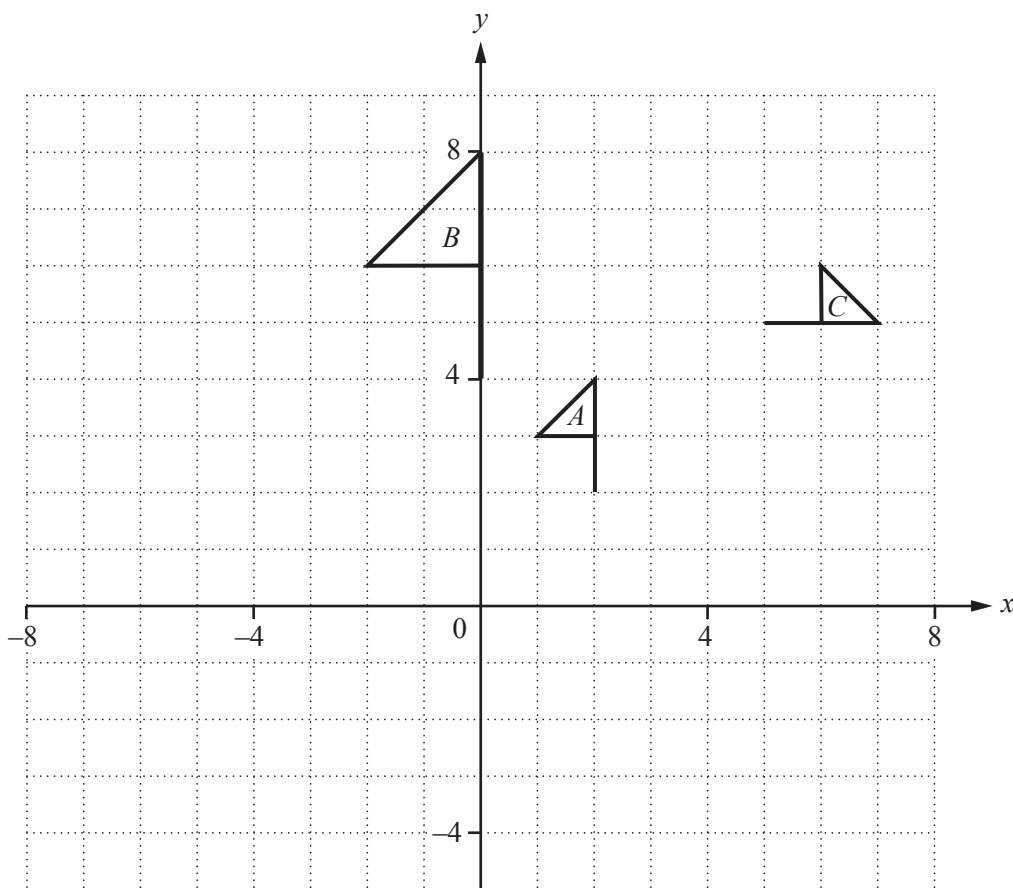

- (i) Flag *A* is mapped onto flag *T* by the translation  $\begin{pmatrix} -3 \\ -6 \end{pmatrix}$ .  
 Draw, and label, flag *T*. [1]
  
- (ii) Describe fully the enlargement that will map flag *A* onto flag *B*.  
 Answer..... [2]
  
- (iii) Find the centre of the rotation that will map flag *A* onto flag *C*.  
 Answer (....., ..... ) [1]
  
- (iv) Rotate flag *B* through  $45^\circ$  anticlockwise about the origin.  
 Label the image *R*. [2]

Permission to reproduce items where third-party owned material protected by copyright is included has been sought and cleared where possible. Every reasonable effort has been made by the publisher (UCLES) to trace copyright holders, but if any items requiring clearance have unwittingly been included, the publisher will be pleased to make amends at the earliest possible opportunity.

To avoid the issue of disclosure of answer-related information to candidates, all copyright acknowledgements are reproduced online in the Cambridge International Examinations Copyright Acknowledgements Booklet. This is produced for each series of examinations and is freely available to download at [www.cie.org.uk](http://www.cie.org.uk) after the live examination series.

Cambridge International Examinations is part of the Cambridge Assessment Group. Cambridge Assessment is the brand name of University of Cambridge Local Examinations Syndicate (UCLES), which is itself a department of the University of Cambridge.