



UNIVERSITY OF CAMBRIDGE INTERNATIONAL EXAMINATIONS  
General Certificate of Education Ordinary Level

---

**PHYSICS**

**5054/01**

Paper 1 Multiple Choice

**May/June 2007**

**1 hour**

Additional Materials:      Multiple Choice Answer Sheet  
   Soft clean eraser  
   Soft pencil (type B or HB is recommended)



---

**READ THESE INSTRUCTIONS FIRST**

Write in soft pencil.

Do not use staples, paper clips, highlighters, glue or correction fluid.

Write your name, Centre number and candidate number on the Answer Sheet in the spaces provided unless this has been done for you.

There are **forty** questions on this paper. Answer **all** questions. For each question there are four possible answers **A, B, C** and **D**.

Choose the **one** you consider correct and record your choice in **soft pencil** on the separate Answer Sheet.

**Read the instructions on the Answer Sheet very carefully.**

Each correct answer will score one mark. A mark will not be deducted for a wrong answer.  
Any rough working should be done in this booklet.

---

This document consists of **19** printed pages and **1** blank page.



- 1 The width of a wooden block is measured using vernier calipers.

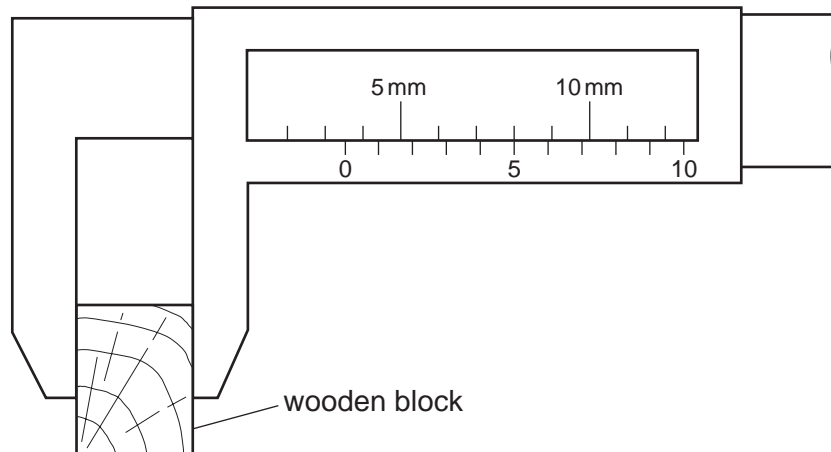

What is the width of the block?

- A** 3.5 mm      **B** 5.3 mm      **C** 8.0 mm      **D** 8.5 mm
- 2 Which of the following correctly lists one scalar and one vector quantity?

	scalar quantity	vector quantity
<b>A</b>	displacement	work
<b>B</b>	energy	force
<b>C</b>	force	acceleration
<b>D</b>	velocity	mass

- 3 A student drops a table-tennis ball in air.

What happens to the velocity and to the acceleration of the ball during the first few seconds after release?

	velocity	acceleration
<b>A</b>	decreases	decreases
<b>B</b>	decreases	increases
<b>C</b>	increases	decreases
<b>D</b>	increases	increases

- 4 A car is brought to rest in 5 s from a speed of 10 m/s.

What is the average deceleration of the car?

- A**  $0.5 \text{ m/s}^2$       **B**  $2 \text{ m/s}^2$       **C**  $15 \text{ m/s}^2$       **D**  $50 \text{ m/s}^2$

- 5 The propeller on a boat pushes water backwards with a force of 2000 N. The boat moves through the water against a total resistive force of 1800 N.

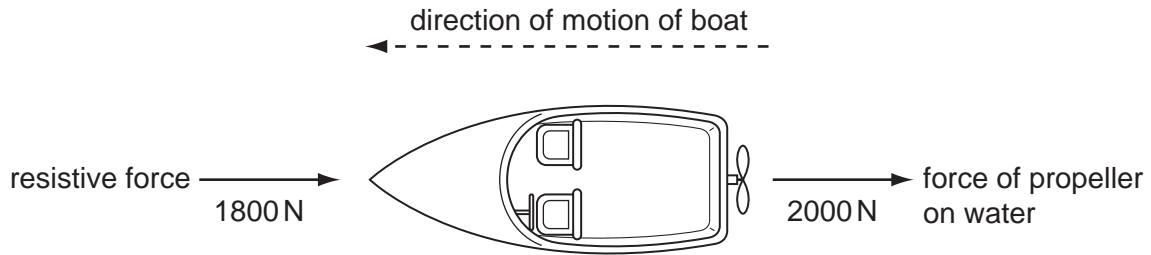

According to Newton's third law, what is the forward force on the propeller due to the water?

- A** 3800 N      **B** 2000 N      **C** 1800 N      **D** 200 N
- 6 A student does an experiment to estimate the density of an irregularly-shaped stone.

Which items of equipment are needed?

- A** a balance and a measuring cylinder containing water  
**B** a balance and a ruler  
**C** a ruler and a measuring cylinder containing water  
**D** only a measuring cylinder containing water

7 Forces are applied to a uniform beam pivoted at its centre.

Which beam is balanced?

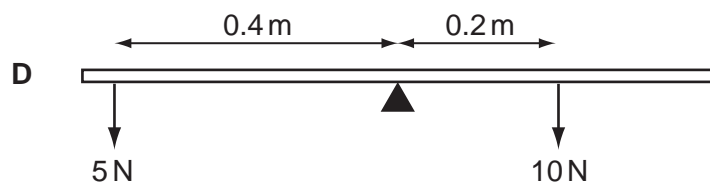
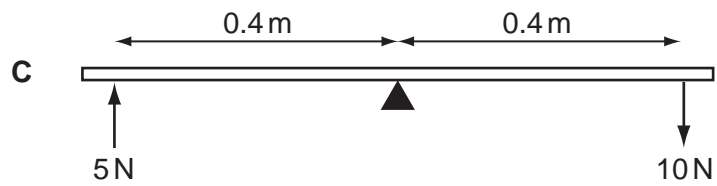
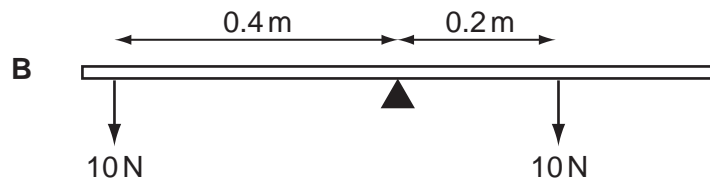
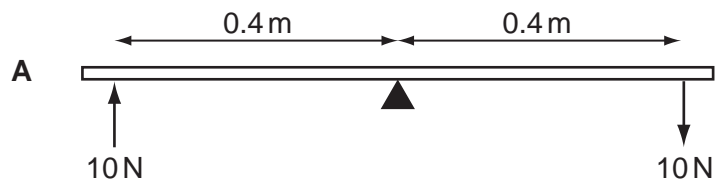

8 A steel spring is stretched by a load. The load is increased.

At first the extension is proportional to the load. The spring reaches its limit of proportionality at L.

Which is the correct graph of the extension against load for the spring?

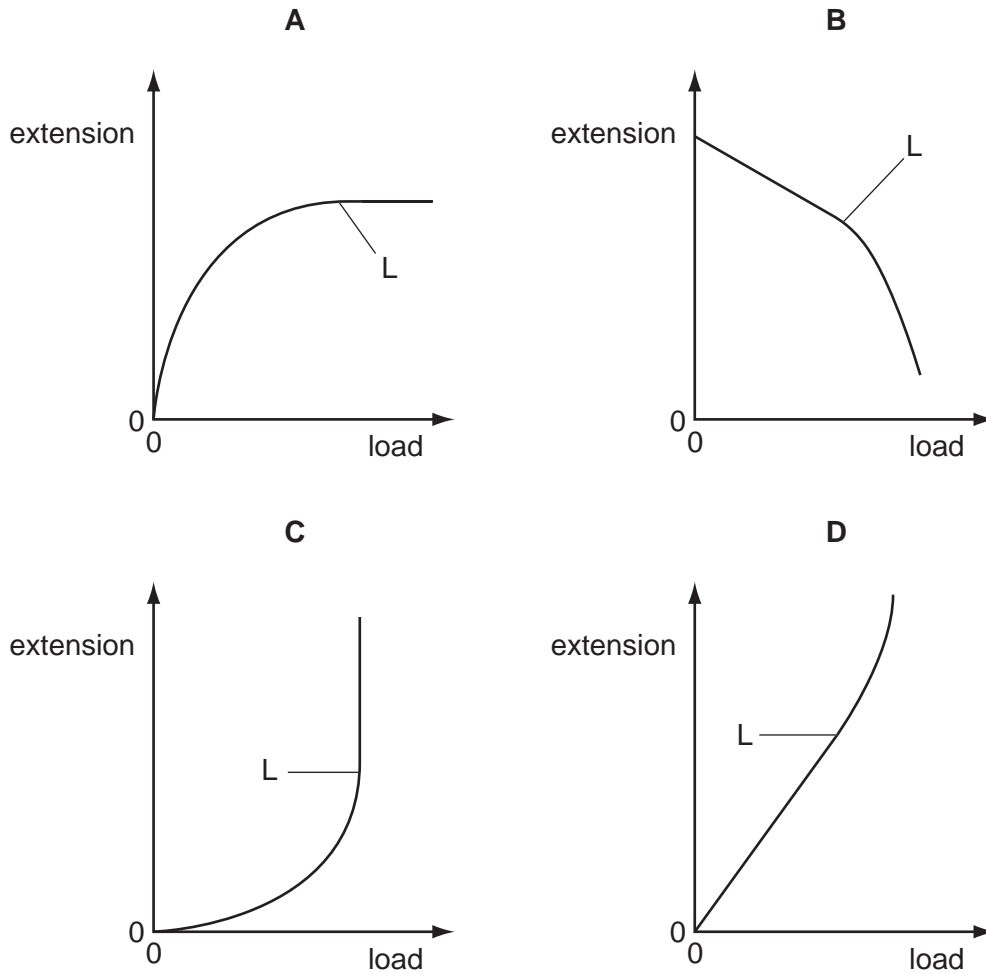

- 9 The diagram shows a battery-operated motor lifting a block of wood at constant speed.

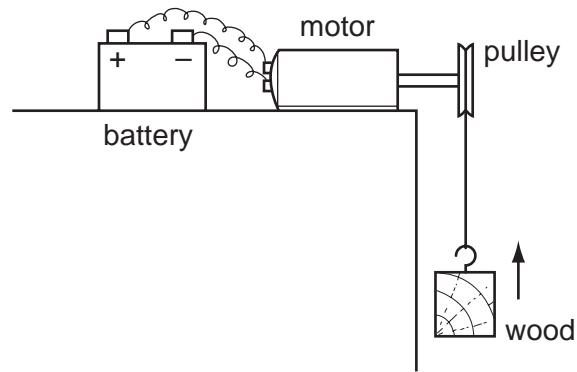

What is the overall energy change taking place?

- A chemical → gravitational potential
  - B gravitational potential → electrical
  - C gravitational potential → kinetic
  - D kinetic → gravitational potential
- 10 Four students exercise in a gym.

Which student does the most work?

	exercise time / s	power developed / W
<b>A</b>	50	250
<b>B</b>	100	150
<b>C</b>	200	200
<b>D</b>	250	30

- 11 Which formula gives the efficiency of an energy conversion?

- A efficiency = total energy input - useful energy output
- B efficiency = useful energy output × total energy input
- C efficiency =  $\frac{\text{useful energy output}}{\text{total energy input}}$
- D efficiency =  $\frac{\text{total energy input}}{\text{useful energy output}}$

- 12 A gas is trapped inside a cylinder by a movable piston. The length of the gas column is 50 cm and the pressure inside the cylinder is  $p$ .

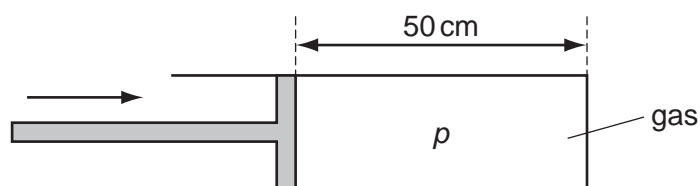

The piston is pushed in a distance of 30 cm, so that the length of the gas column is now 20 cm. The temperature of the gas does not change.

What is the new pressure of the gas?

- A  $0.4p$                       B  $0.6p$                       C  $1.5p$                       D  $2.5p$
- 13 A liquid is heated.
- Which statement is **incorrect**?
- A The molecules expand.  
 B The molecules gain energy.  
 C The molecules move further apart.  
 D The molecules move faster.
- 14 What describes the molecular structure of a liquid?

	distance between the molecules	motion of the molecules	strength of forces between the molecules
A	close together	stationary	very strong
B	close together	random	fairly strong
C	far apart	stationary	fairly strong
D	far apart	random	weak

- 15 A thermocouple thermometer uses a voltmeter to measure the e.m.f. generated between two junctions. The junctions are at temperatures  $t_1$  and  $t_2$ . To calibrate the thermometer, fixed points are needed.

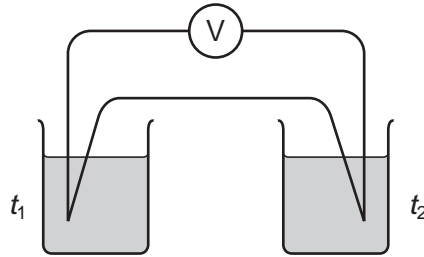

What are the values of  $t_1$  and  $t_2$  when the thermometer is calibrated at the steam point?

	$t_1$	$t_2$
<b>A</b>	0 °C	0 °C
<b>B</b>	0 °C	100 °C
<b>C</b>	25 °C	0 °C
<b>D</b>	25 °C	125 °C

- 16 What is the definition of *heat capacity*?
- A** the quantity of heat required to raise the temperature of an object through 1 °C
  - B** the quantity of heat required to raise the temperature of 1 kg of a substance through 1 °C
  - C** the quantity of heat required to convert an object from solid to liquid without a change in temperature
  - D** the quantity of heat required to change 1 kg of a substance from solid to liquid without a change in temperature
- 17 Fillings in teeth should be made from a material which
- A** expands more than the tooth when heated.
  - B** expands by the same amount as the tooth when heated.
  - C** expands less than the tooth when heated.
  - D** does not expand when heated.



- 18 A double-glazed window has two sheets of glass separated by a layer of air.

Thermal energy is conducted and convected through the layer of air. The amount of conduction and convection varies with the thickness of the layer of air, as shown in the graph.

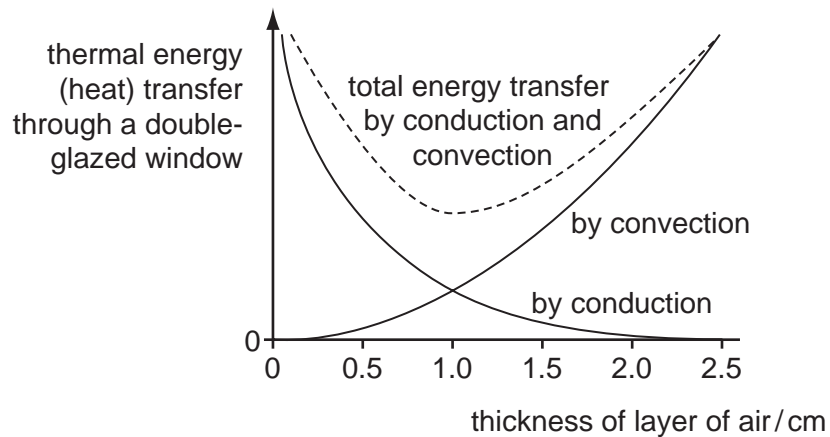

Which thickness of air produces the smallest energy transfer, and why?

- A 0.5 cm because there is little convection  
 B 1.0 cm because the total thermal energy transfer is least  
 C 1.5 cm because the total thermal energy transfer is small and conduction is low  
 D 2.0 cm because there is little conduction
- 19 The diagram shows a water wave in a ripple tank.

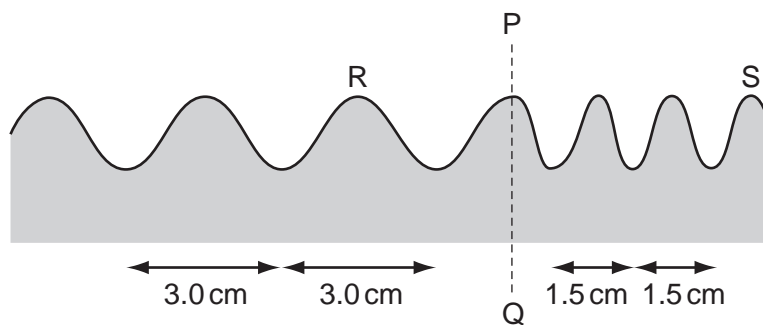

The wave has a speed of 12 cm/s at R.

The wave crosses a boundary PQ where the distance between crests changes from 3.0 cm to 1.5 cm.

What is the speed of the wave at S?

- A 3.0 cm/s      B 6.0 cm/s      C 12 cm/s      D 24 cm/s

20 The diagram shows a child using a periscope to look at an object on the other side of a wall.

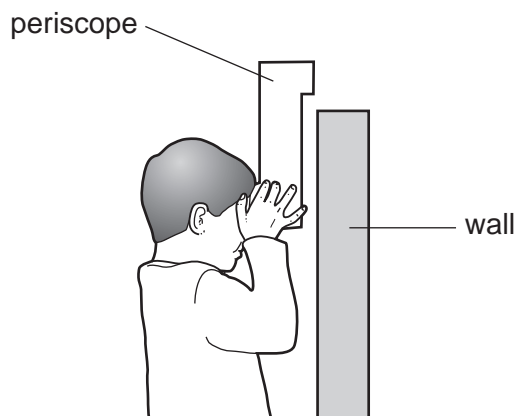

Which diagram shows a correctly drawn ray of light from the object?

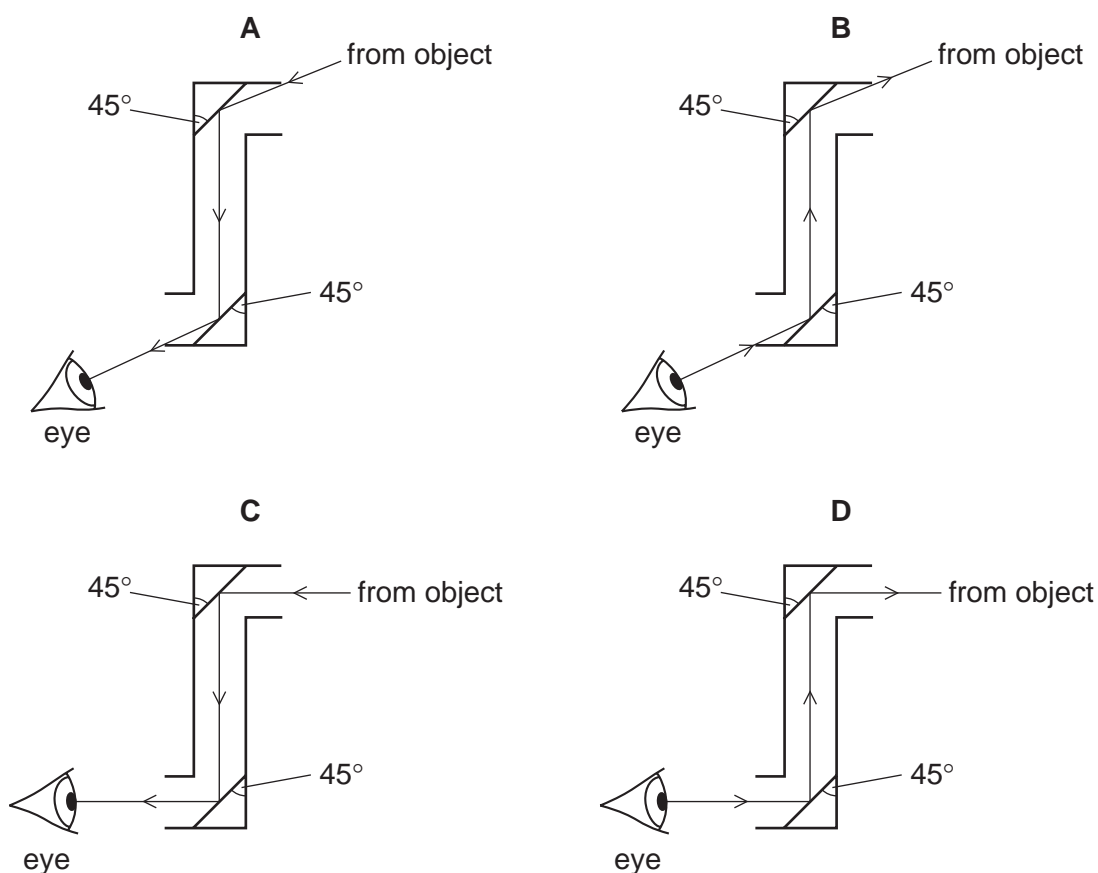

21 What happens to light as it passes from glass into air?

- A Its frequency decreases because its speed decreases.
- B Its frequency increases because its speed increases.
- C Its wavelength decreases because its speed decreases.
- D Its wavelength increases because its speed increases.

22 Which type of wave is used to send telephone signals to and from a satellite?

- A infra-red waves
- B light waves
- C microwaves
- D sound waves

23 A girl, standing 150 m in front of a tall building, fires a shot using a starting pistol. A boy, standing 350 m from the girl, hears two bangs 1 s apart.

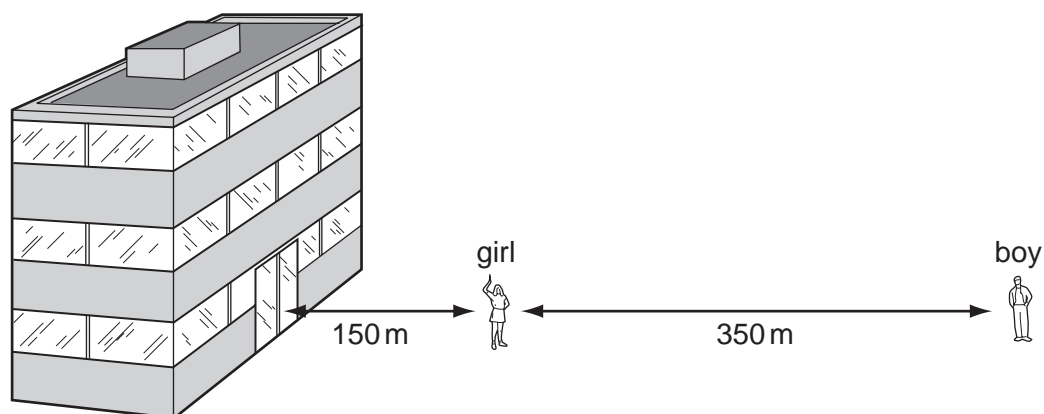

From this information, what is the speed of sound in air?

- A 300 m/s
- B 350 m/s
- C 500 m/s
- D 650 m/s

24 The diagram shows a brass rod and an iron rod beside each other at the bottom of a rectangular coil.

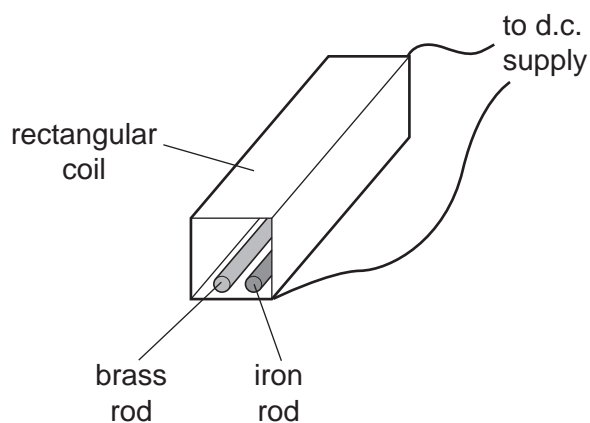

What happens when a d.c. current passes through the coil?

- A Only the brass rod is magnetised.
- B Only the iron rod is magnetised.
- C The two rods attract each other.
- D The two rods repel each other.

25 Four metal rods are placed, in turn, inside a coil of copper wire.

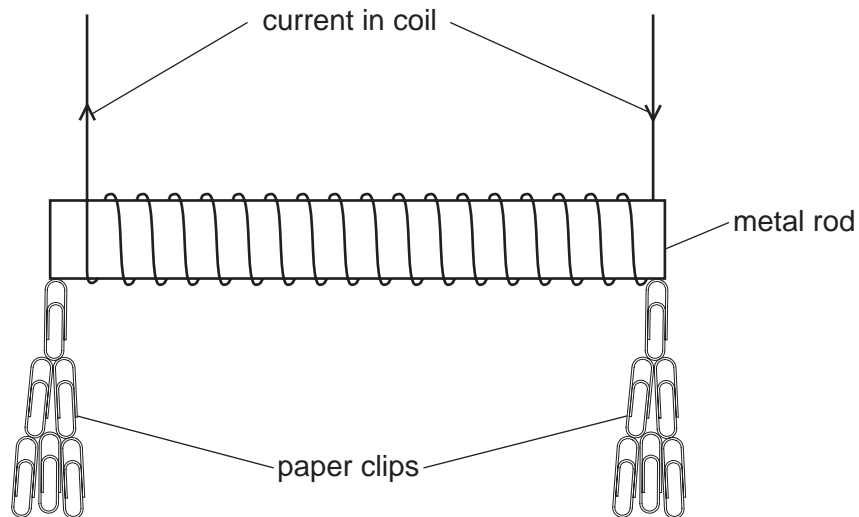

Each rod is used to pick up as many paper clips as possible. The current is then switched off.

The table gives the results of the experiment.

Which rod is the most suitable core for a coil in a circuit breaker?

	number of paper clips picked up when there is a current in the coil	number of paper clips still attached after the current is switched off
<b>A</b>	1	0
<b>B</b>	20	2
<b>C</b>	35	0
<b>D</b>	35	30

- 26 Two uncharged metal spheres, not touching one another, are suspended by means of cotton thread. A positively charged rod is brought near.

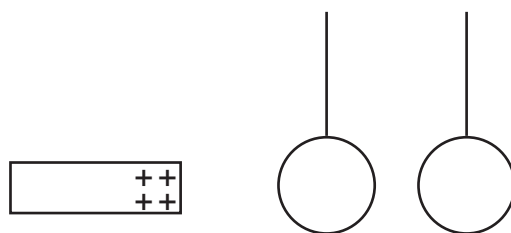

Which diagram shows what happens to the spheres?

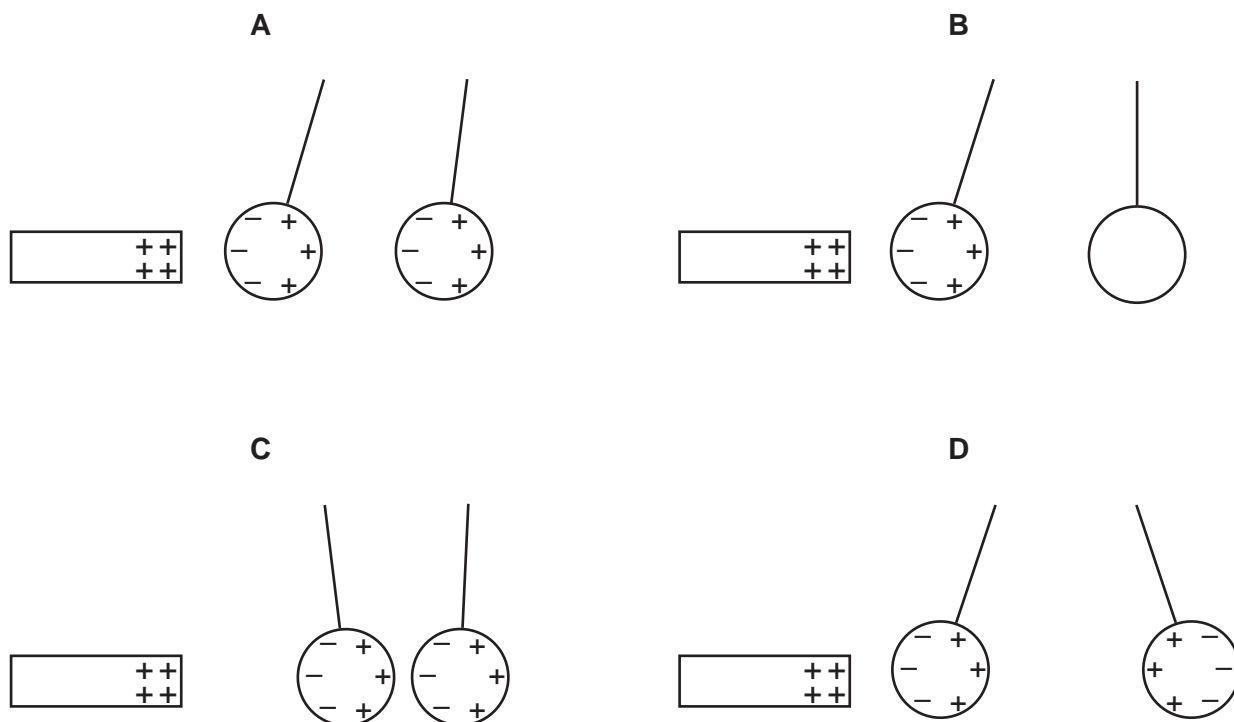

- 27 Which factors will both increase the resistance of a wire in a circuit?

	size of wire	temperature of wire
<b>A</b>	longer	lower
<b>B</b>	shorter	lower
<b>C</b>	thicker	higher
<b>D</b>	thinner	higher

- 28 Which graph best represents how current  $I$  varies with voltage  $V$  in a component in which the resistance **increases** as the current **increases**.

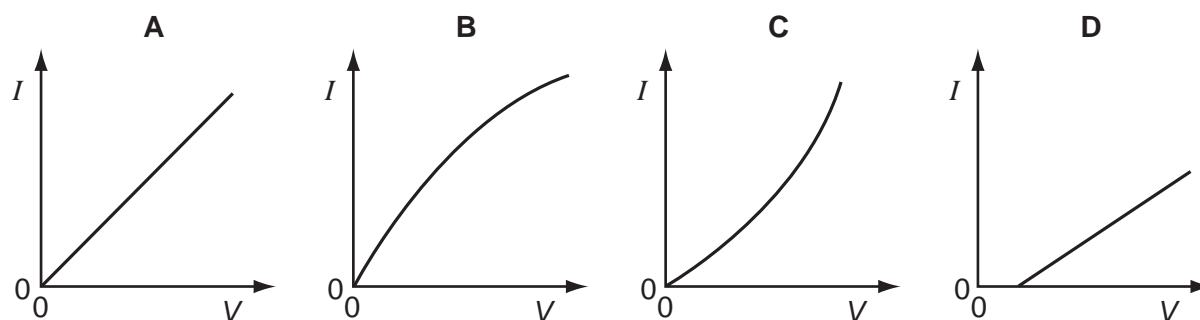

- 29 At which point in the circuit is the current the smallest?

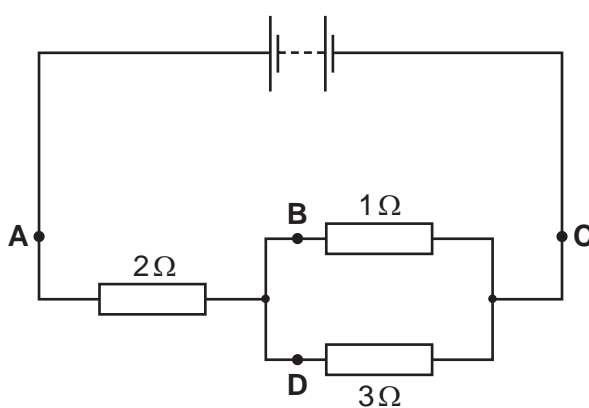

- 30 The diagram shows a circuit.

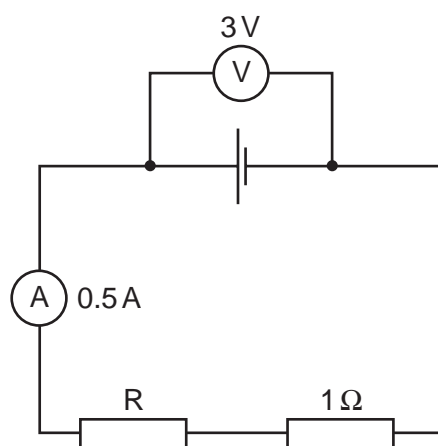

The ammeter has negligible resistance.

What is the resistance of the resistor  $R$ ?

- A  $0.5\Omega$       B  $1.5\Omega$       C  $5\Omega$       D  $6\Omega$

31 The diagram shows the circuit for a hair-dryer.

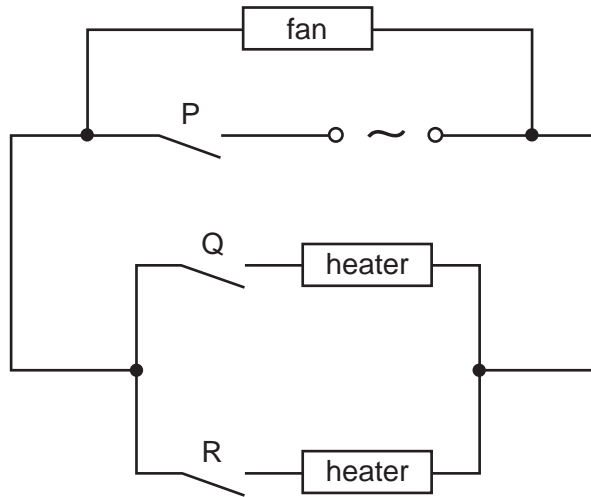

The fan has a power rating of 0.1 kW and the heaters each have a rating of 0.4 kW. The cost of electricity is 8 cents/kWh.

What is the cost of running the dryer for two hours with switches P and Q closed and switch R open?

- A** 1.6 cents      **B** 3.2 cents      **C** 6.4 cents      **D** 8.0 cents

32 Which circuit shows the correct positions for the fuse and the switch in the lighting circuit of a house?

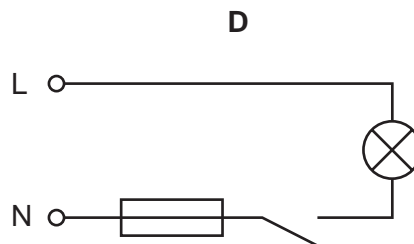
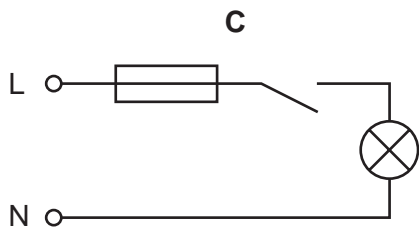
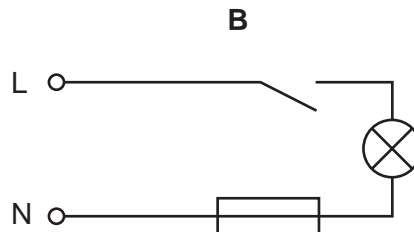
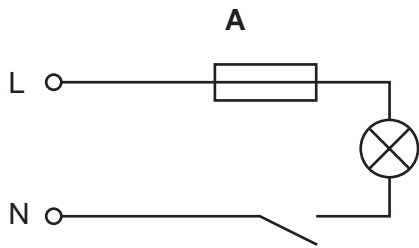

key

L = live wire

N = neutral wire

- 33 The diagrams show the forces  $F$  between two wires carrying currents out of the page. The magnetic fields close to the wires are also shown.

Which diagram is correct?

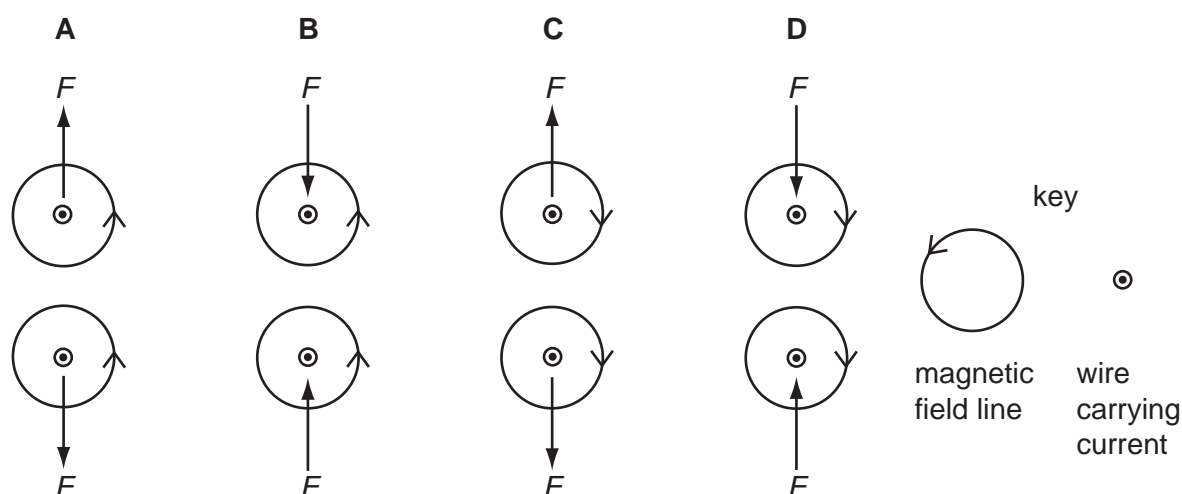

- 34 In a d.c. motor, the coil is wound on a soft iron cylinder.

Why is soft iron used?

- A to increase the strength of the magnetic field
  - B to increase the weight of the coil
  - C to insulate the coil from the magnet
  - D to prevent the coil from spinning too quickly
- 35 The diagram shows how a magnet and a coil may be used to induce an electric current.

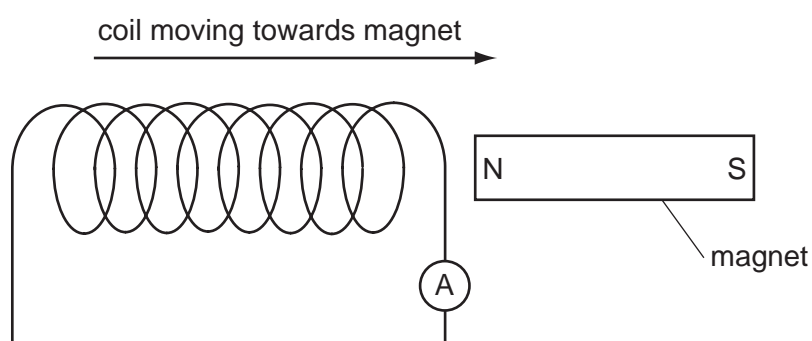

How could the ammeter reading be increased?

- A Move the coil more slowly.
- B Put a resistor in series with the ammeter.
- C Turn the magnet round, then move the coil.
- D Use a coil with more turns.



36 A simple a.c. generator produces an alternating e.m.f. as shown.

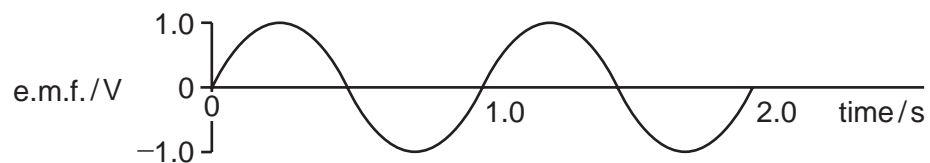

The speed of the generator is doubled.

Which graph best represents the new output?

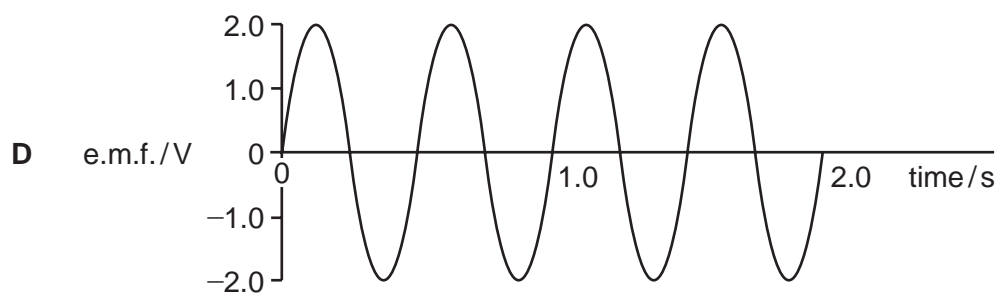
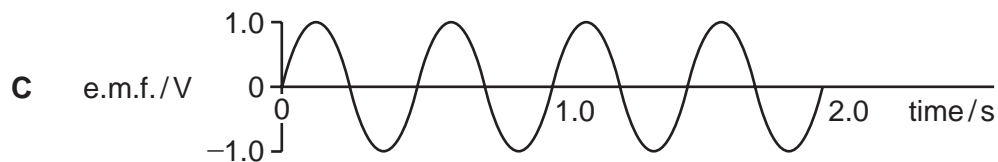
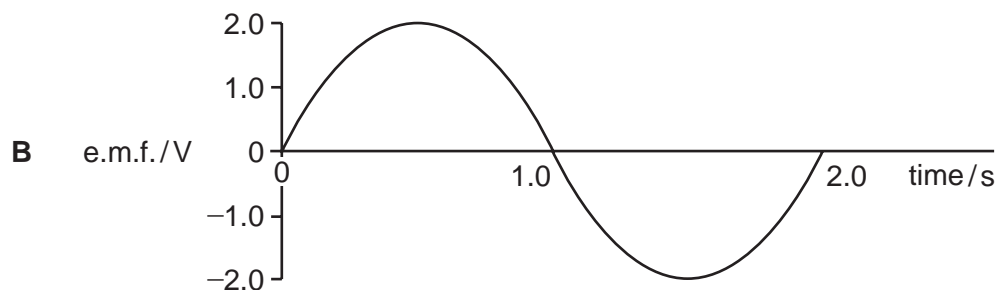
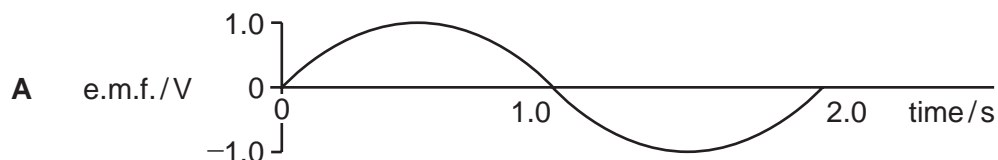

- 37 A waveform is displayed on a cathode-ray oscilloscope. The length of three cycles of the waveform is 6 cm. The vertical gain and the time-base settings are shown on the diagram.

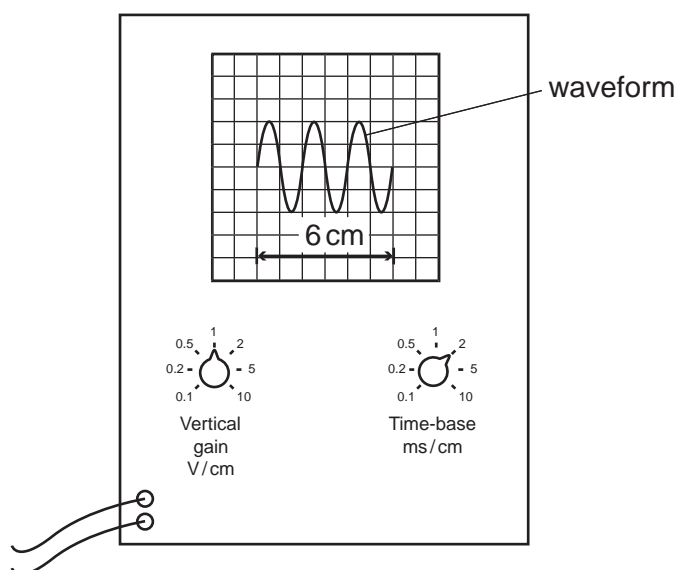

What is the time taken for one cycle of the waveform?

- A** 1 ms                      **B** 2 ms                      **C** 4 ms                      **D** 6 ms
- 38 Which statement is true for all three types of radioactive emission (alpha-particles, beta-particles and gamma-rays)?
- A** They are completely absorbed by a thin aluminium sheet.
- B** They are deflected by electric fields.
- C** They emit light.
- D** They ionise gases.

- 39 The diagram shows one type of radiation passing between the poles of a strong magnet and being detected.

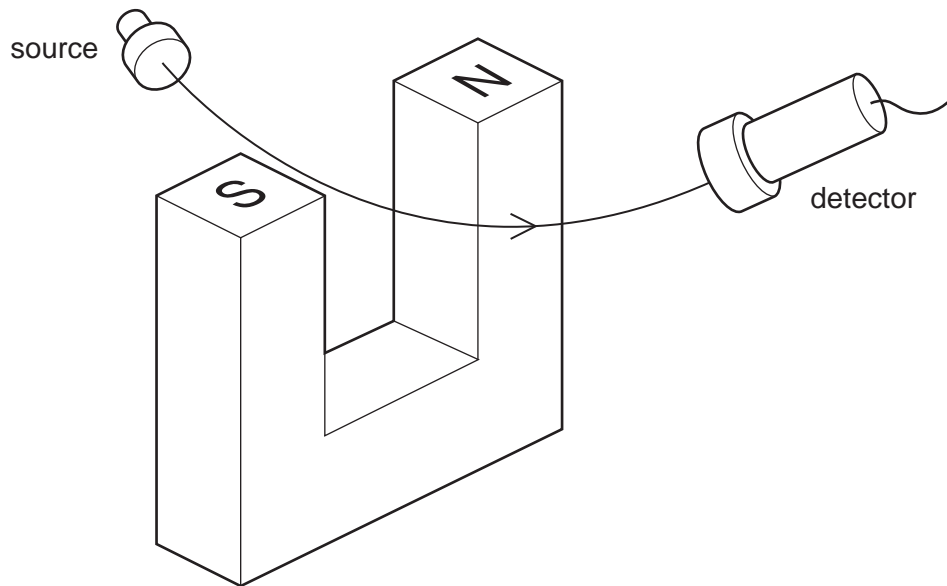

Which type of radiation is being detected?

- A alpha-particles only
  - B beta-particles only
  - C gamma-rays only
  - D alpha-particles and beta-particles
- 40 A nuclide has the notation  ${}_{23}^{48}\text{X}$ .

Which line in the table describes a different isotope of this nuclide?

	proton number (atomic number)	nucleon number (mass number)
<b>A</b>	23	50
<b>B</b>	24	48
<b>C</b>	48	24
<b>D</b>	50	23

**BLANK PAGE**

---

Permission to reproduce items where third-party owned material protected by copyright is included has been sought and cleared where possible. Every reasonable effort has been made by the publisher (UCLES) to trace copyright holders, but if any items requiring clearance have unwittingly been included, the publisher will be pleased to make amends at the earliest possible opportunity.

University of Cambridge International Examinations is part of the Cambridge Assessment Group. Cambridge Assessment is the brand name of University of Cambridge Local Examinations Syndicate (UCLES), which is itself a department of the University of Cambridge.