



Cambridge International Examinations
Cambridge International General Certificate of Secondary Education

CANDIDATE
NAME

--

CENTRE
NUMBER

--	--	--	--	--

CANDIDATE
NUMBER

--	--	--	--



DESIGN AND TECHNOLOGY

0445/32

Paper 3 Resistant Materials

October/November 2015

1 hour

Candidates answer on the Question Paper.

No Additional Materials are required.

READ THESE INSTRUCTIONS FIRST

Write your Centre number, candidate number and name on all the work you hand in.

Write in blue or black pen.

You may use an HB pencil for any diagrams, graphs or rough working.

Do not use staples, paper clips, glue or correction fluid.

DO NOT WRITE IN ANY BARCODES.

Section A

Answer **all** questions in this section.

Section B

Answer **one** question in this section.

You may use a calculator.

At the end of the examination, fasten all your work securely together.

The number of marks is given in brackets [] at the end of each question or part question.

The total of the marks for this paper is 50.

This document consists of **15** printed pages and **1** blank page.

Section A

Answer **all** questions in this section.

1 Give **three** pieces of information needed when ordering nuts and bolts.

- 1
- 2
- 3 [3]

2 Complete the drawing below to show a coping saw.

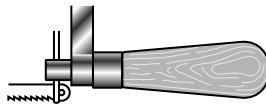

[2]

3 Fig. 1 shows a wooden frame construction glued and clamped.

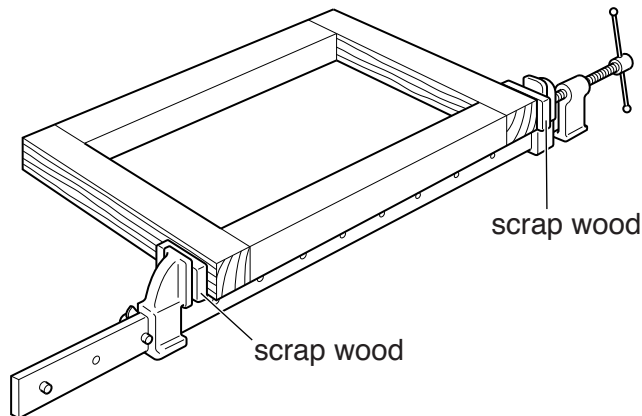

Fig. 1

(a) Name the type of clamp used.

.....

(b) Give **one** reason why pieces of scrap wood are used.

..... [2]

4 Underline the **two** 'smart' materials in the list below.

aluminium **polymorph** **nitinol** **fibreglass** **nylon** [2]

5 Complete the table below by naming each tool and giving a specific use.

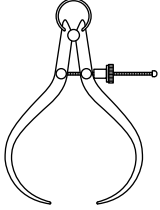
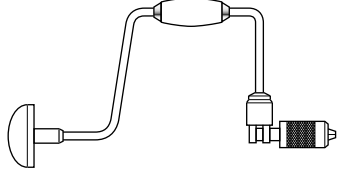
Tool	Specific name	Specific use
		
		

[4]

6 Fig. 2 shows a veneer being cut from a log.

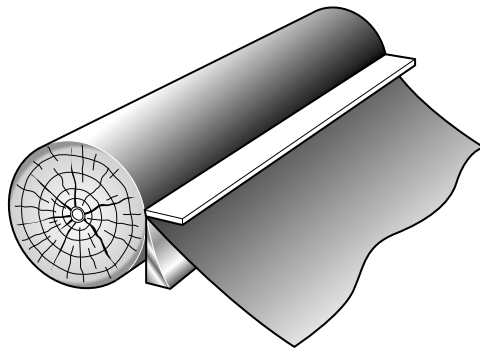

Fig. 2

(a) Give **one** advantage of using veneers when making furniture.

.....

(b) Give **one** disadvantage of using veneers when making furniture.

..... [2]

- 7 Fig. 3 shows part of a wooden frame.
Add to Fig. 3 to show how the corner joint could be strengthened.

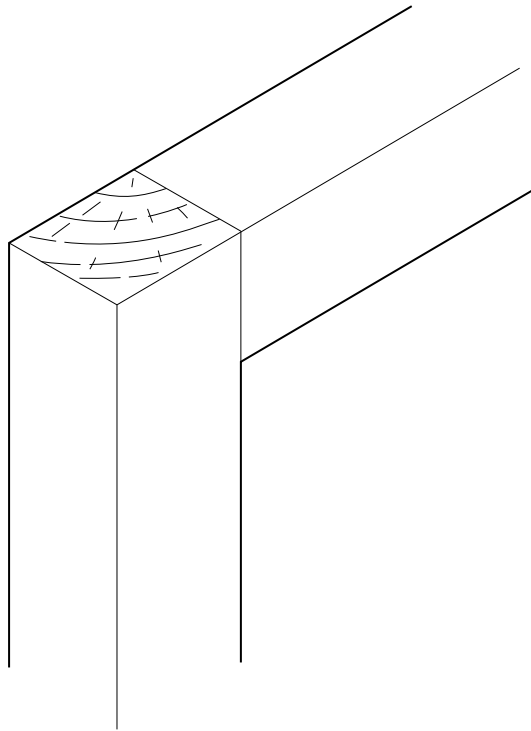

Fig. 3

[2]

- 8 Fig. 4 shows a handle made from aluminium alloy.

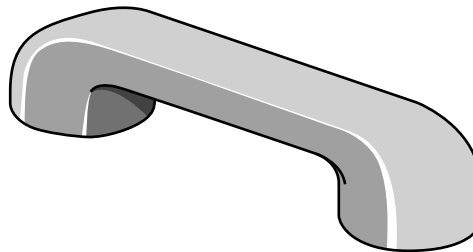

Fig. 4

- (a) Name the process used to make the handle.

.....

- (b) Give **one** suitable finish for the handle.

..... [2]

9 Fig. 5 shows a block of wood with a shape marked out ready to be removed.

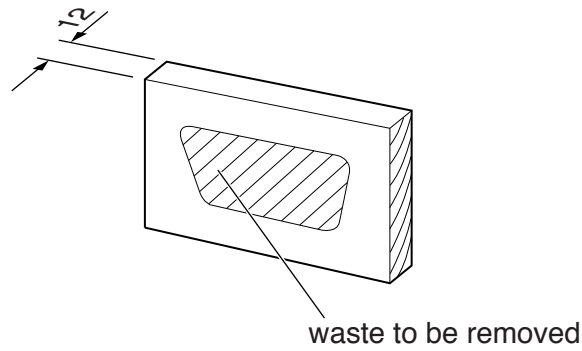

Fig. 5

Describe **three** main stages in removing the waste wood and producing clean, smooth edges.

- 1
- 2
- 3 [3]

10 Fig. 6 shows two different wooden chairs.

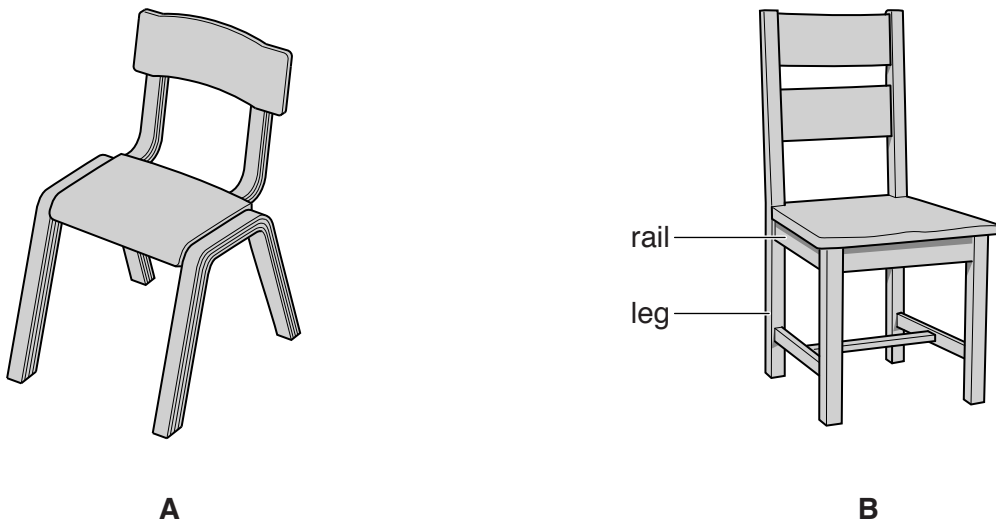

Fig. 6

(a) Name the process used to produce the legs in chair **A**.

.....

(b) Name **one** construction that could be used to join the legs and rails in chair **B**.

.....

(c) Give **one** advantage of the construction of chair **A** over chair **B**.

..... [3]

Section B

Answer **one** question in this section.

- 11** Fig. 7 shows views of a computer desk made from 15 mm thick manufactured board. The computer desk will be sold as flat-pack furniture for self-assembly.

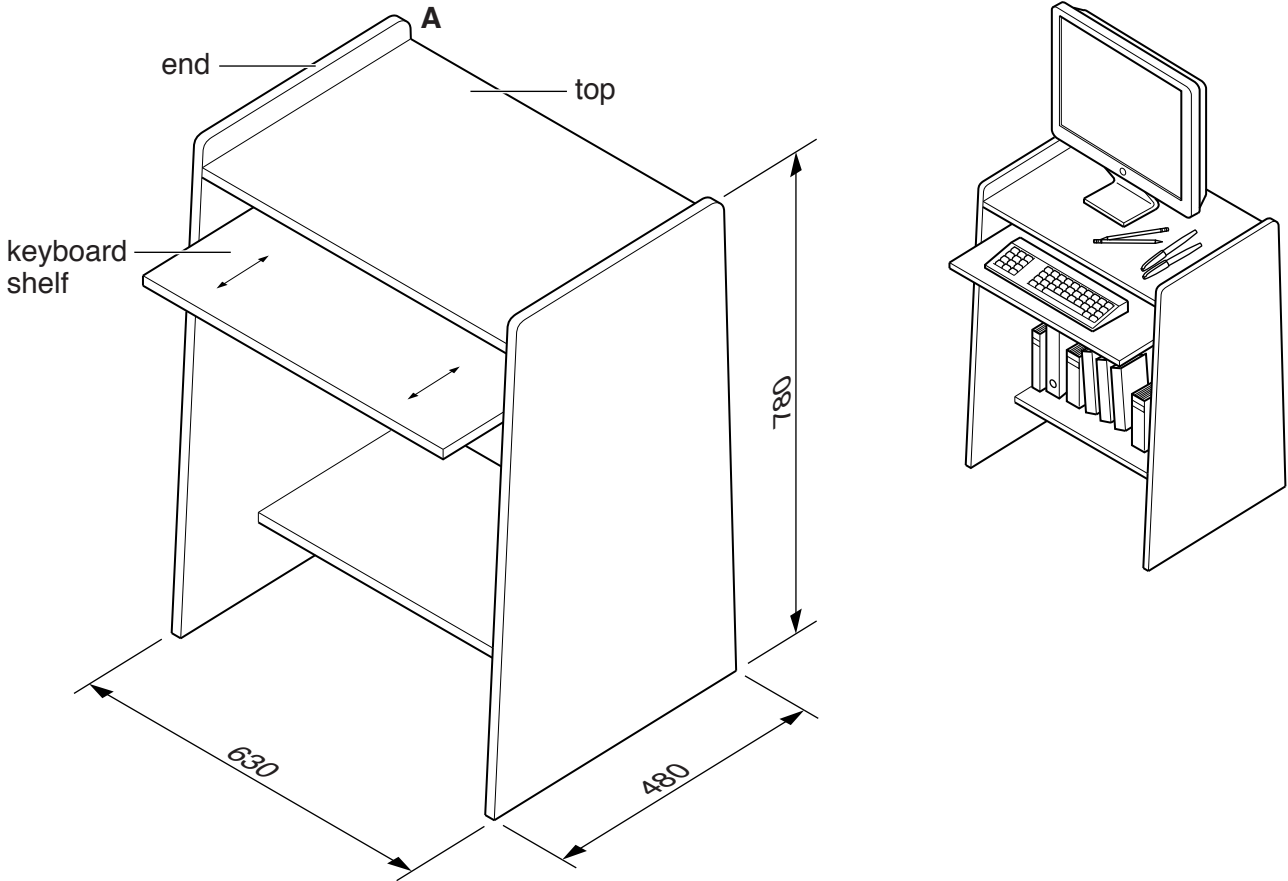

Fig. 7

(a) Give **two** benefits of flat-pack furniture for:

(i) the consumer;

1

2 [2]

(ii) the manufacturer.

1

2 [2]

- (b) Use sketches and notes to show how knock-down (KD) fittings could be used to join the top to one end at **A**.

[4]

- (c) Use sketches and notes to show how the keyboard shelf could be made to move in and out as shown in Fig. 7. Include details of materials and constructions used.

[4]

(d) The ends and shelves will be spray painted.

(i) Give **two** advantages of spray painting rather than applying paint with a brush.

- 1
- 2 [2]

(ii) Describe **two** safety precautions you would take when spray painting.

- 1
- 2 [2]

(e) Evaluate the design of the computer desk shown in Fig. 7 in terms of:

(i) safety;

-
- [2]

(ii) appearance;

-
- [2]

(iii) costs.

-
- [2]

(f) Explain why the computer desk could be considered to have a limited lifetime.

-
-
-
- [3]

BLANK PAGE

Question 12 is printed on the next page.

Permission to reproduce items where third-party owned material protected by copyright is included has been sought and cleared where possible. Every reasonable effort has been made by the publisher (UCLES) to trace copyright holders, but if any items requiring clearance have unwittingly been included, the publisher will be pleased to make amends at the earliest possible opportunity.

To avoid the issue of disclosure of answer-related information to candidates, all copyright acknowledgements are reproduced online in the Cambridge International Examinations Copyright Acknowledgements Booklet. This is produced for each series of examinations and is freely available to download at www.cie.org.uk after the live examination series.

Cambridge International Examinations is part of the Cambridge Assessment Group. Cambridge Assessment is the brand name of University of Cambridge Local Examinations Syndicate (UCLES), which is itself a department of the University of Cambridge.

- 12 Fig. 8 shows an incomplete design for a freestanding barbecue. The barbecue body is made from 1 mm thick mild steel sheet.

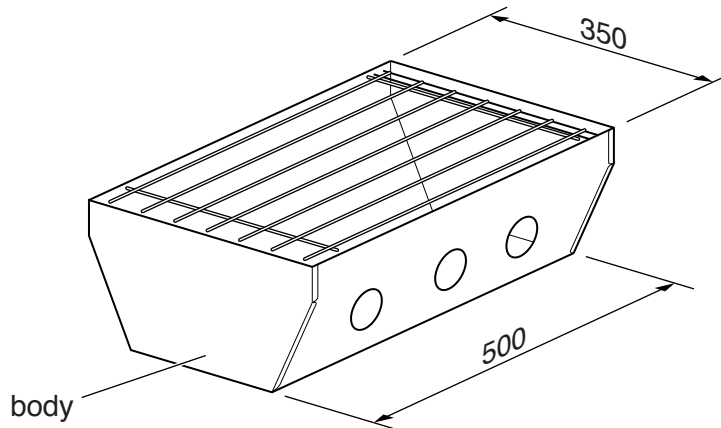

Fig. 8

- (a) Give **two** reasons why mild steel is suitable for the barbecue body.

1

2 [2]

- (b) Give **one** reason why the mild steel sheet would need an applied finish.

..... [1]

- (c) Fig. 9 shows one end of the barbecue body marked out, ready to be cut to shape.

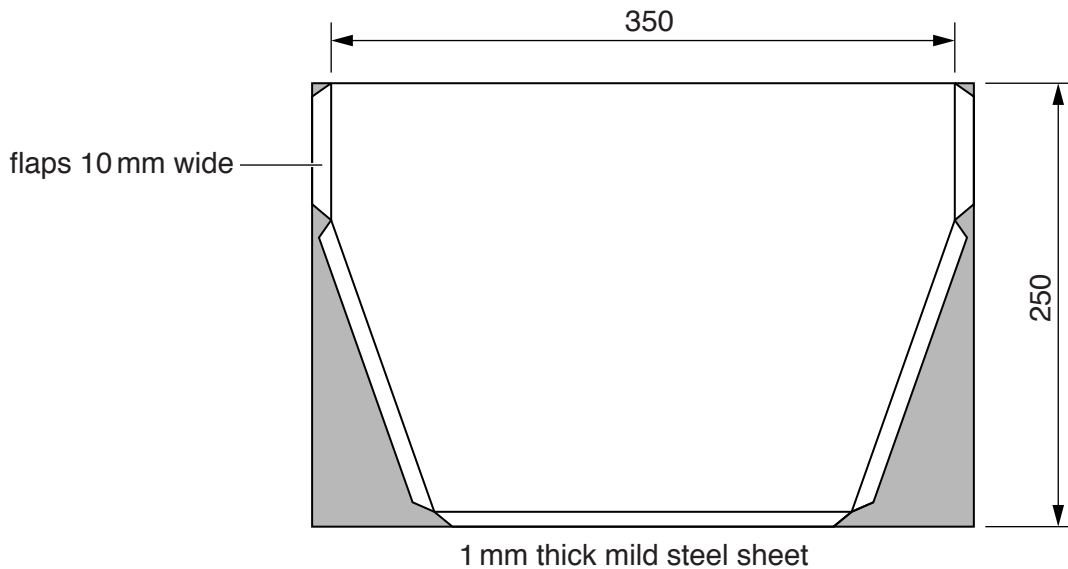

Fig. 9

Use sketches and notes to show how the shape could be cut out.
Name all the tools and equipment.

[4]

(d) Fig. 10 shows one end of the barbecue body with flaps bent to 90° .

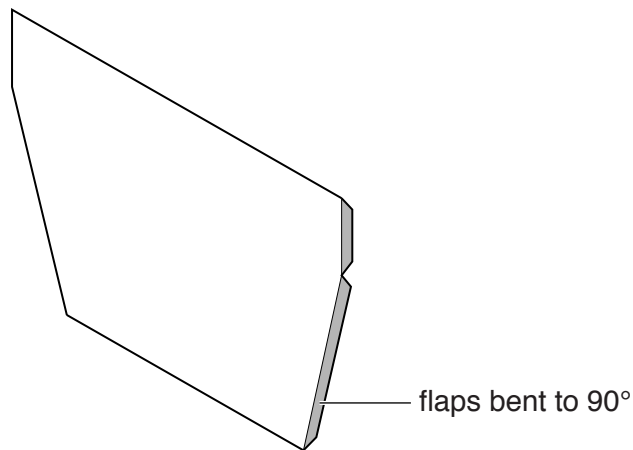

Fig. 10

Use sketches and notes to show how the flaps could be bent to 90° .

(e) Sketch **one** permanent method of joining the ends to the sides of the barbecue body.

[2]

(f) Use sketches and notes to show how the barbecue body could be supported at a height of 500 mm above the ground.

Your design must include:

- named materials;
- two important sizes;
- a temporary method of joining the support to the barbecue body.

[8]

(g) Fig. 11 shows three tools commonly used with the barbecue.

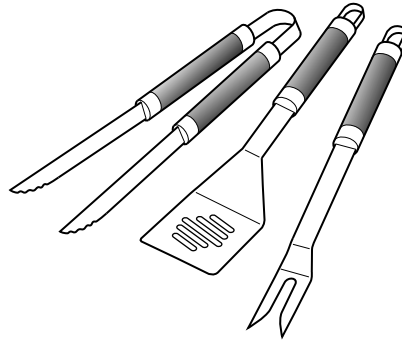

Fig. 11

Use sketches and notes to design a rack for the three tools that could be fixed to the barbecue body.
Include details of materials and constructions used.

[5]

13 Fig. 12 shows a palette used to mix paints. The palette is vacuum formed.

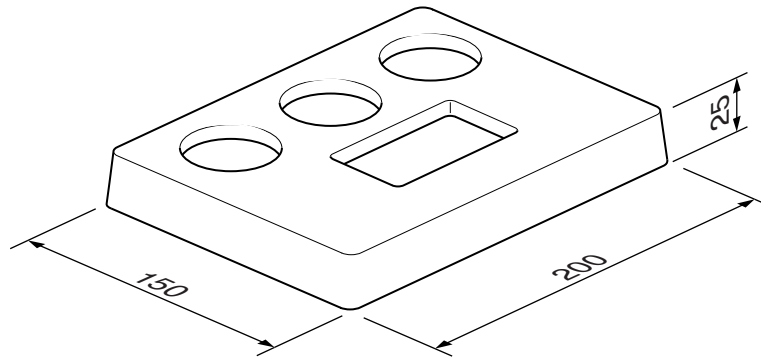

Fig. 12

(a) (i) Name a suitable plastic for the palette.

..... [1]

(ii) A former made from MDF is used to vacuum form the palette.
Give **two** advantages of using MDF rather than solid wood for the former.

1

2 [2]

(iii) Describe **two** considerations you would take into account when making a former used to vacuum form the palette.

1

2 [2]

(b) Use detailed sketches and notes to show how the palette would be vacuum formed.

(c) Fig. 13 shows a holder used when mixing paints.

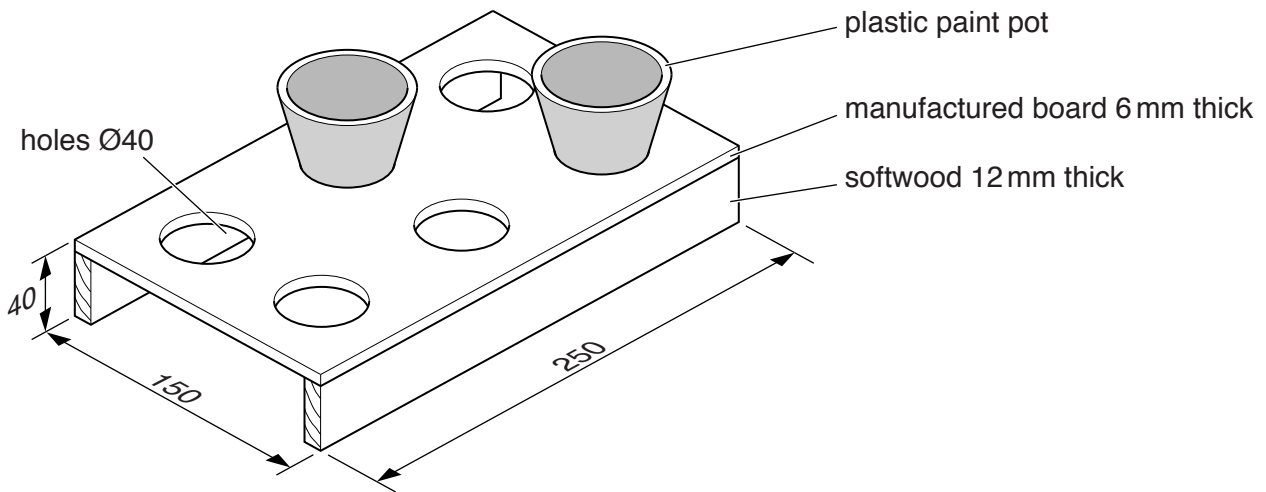

Fig. 13

(i) Name a manufacturing process, other than vacuum forming, used to produce the plastic paint pots.

..... [1]

(ii) Use sketches and notes to show how the manufactured board top would be held securely while the holes for the paint pots are drilled.

[3]

Question 13 continues on the following page.

- (iii) Use sketches and notes to show how the manufactured board top could be joined permanently to the softwood sides.

[3]

- (d) Fig. 14 shows three paintbrushes that will be stored with the holder shown in Fig. 13.

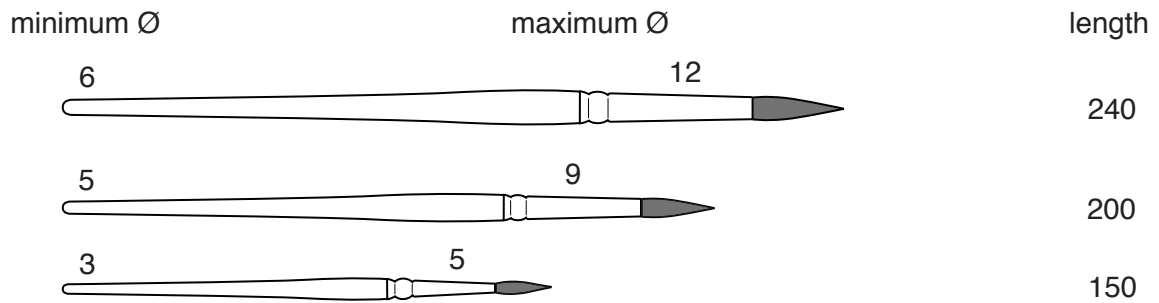

Fig. 14

Use sketches and notes to show a modification to the holder so that the three paintbrushes could be stored safely. Include details of materials, constructions and sizes.

[5]