

# Cambridge IGCSE™

CANDIDATE  
NAMECENTRE  
NUMBER

--	--	--	--	--

CANDIDATE  
NUMBER

--	--	--	--

**MATHEMATICS****0580/21**

Paper 2 (Extended)

**October/November 2020****1 hour 30 minutes**

You must answer on the question paper.

You will need: Geometrical instruments

**INSTRUCTIONS**

- Answer **all** questions.
- Use a black or dark blue pen. You may use an HB pencil for any diagrams or graphs.
- Write your name, centre number and candidate number in the boxes at the top of the page.
- Write your answer to each question in the space provided.
- Do **not** use an erasable pen or correction fluid.
- Do **not** write on any bar codes.
- You should use a calculator where appropriate.
- You may use tracing paper.
- You must show all necessary working clearly.
- Give non-exact numerical answers correct to 3 significant figures, or 1 decimal place for angles in degrees, unless a different level of accuracy is specified in the question.
- For  $\pi$ , use either your calculator value or 3.142.

**INFORMATION**

- The total mark for this paper is 70.
- The number of marks for each question or part question is shown in brackets [ ].

---

This document has **12** pages. Blank pages are indicated.

1 Simplify.

$$3a + 7b - 4a + b$$

..... [2]

2 A field,  $ABC$ , is in the shape of a triangle.  
 $AC = 500$  m and  $BC = 650$  m.

**Using a ruler and compasses only**, complete the scale drawing of the field  $ABC$ .

Leave in your construction arcs.

Use a scale of 1 cm to represent 100 m.

The side  $AB$  has been drawn for you.



Scale: 1 cm to 100 m

[3]

3 Rangan buys 3.6 kg of potatoes and 2.8 kg of leeks.  
 The total cost is \$13.72 .  
 Leeks cost \$2.65 per kilogram.

Find the cost of 1 kg of potatoes.

\$ ..... [3]

- 4 Aisha records the distance she runs and her average speed. The results are shown in the scatter diagram.

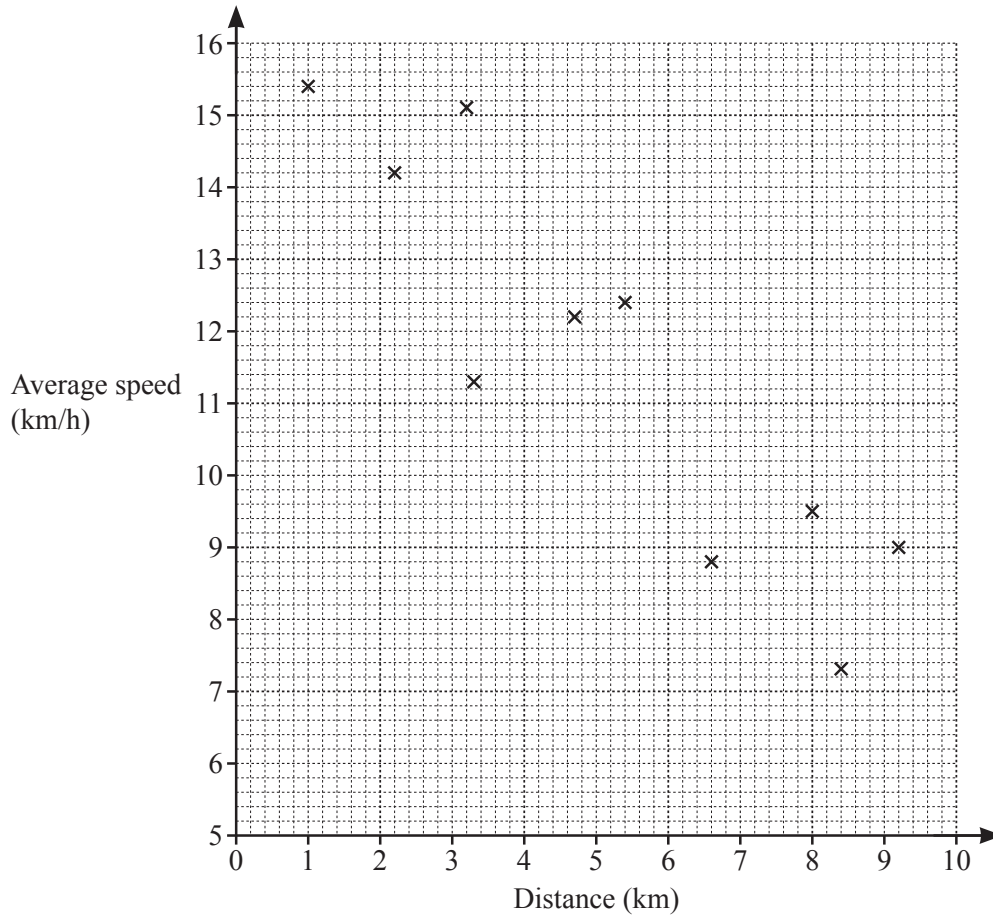

- (a) The table shows the results of four more runs.

Distance (km)	4.2	5.7	7.1	8.8
Average speed (km/h)	13.4	11.8	9.8	8.3

On the scatter diagram, plot these points. [2]

- (b) What type of correlation is shown in the scatter diagram?

..... [1]

- (c) On the scatter diagram, draw a line of best fit. [1]

- (d) Use your line of best fit to estimate her average speed when she runs a distance of 6 km.

..... km/h [1]

5 
$$T = \frac{49.2 - 9.59}{4.085 \times 2.35}$$

By writing each number correct to 1 significant figure, work out an estimate for  $T$ .  
You must show all your working.

..... [2]

6 **Without using a calculator**, work out  $2\frac{2}{3} \times 2\frac{3}{4}$ .

You must show all your working and give your answer as a mixed number in its simplest form.

..... [3]

7 Make  $x$  the subject of this formula.

$$2y = 5x - 7$$

$x =$  ..... [2]

- 8 (a) 1, 2, 3, 5 and 7 are all common factors of two numbers.

Write down the digit that the two numbers must end in.

..... [1]

- (b) Write 84 as a product of its prime factors.

..... [2]

- 9 (a) Ahmed increases 40 by 300%.

From this list, put a ring around the correct calculation.

$40 \times 1.300$

$40 \times 3$

$40 \times 400$

$40 \times 4$

$40 \times 300$

[1]

- (b) Ahmed finds the magnitude of the vector  $\begin{pmatrix} 2 \\ -3 \end{pmatrix}$ .

From this list, put a ring around the correct calculation.

$\sqrt{2^2 + -3^2}$

$2^2 - 3^2$

$\sqrt{2^2 - 3^2}$

$2^2 + (-3)^2$

$\sqrt{2^2 + (-3)^2}$

[1]

- 10 A town has a population of 45 000.

This population increases exponentially at a rate of 1.6% per year.

Find the population of the town at the end of 5 years.

Give your answer correct to the nearest hundred.

..... [3]

11

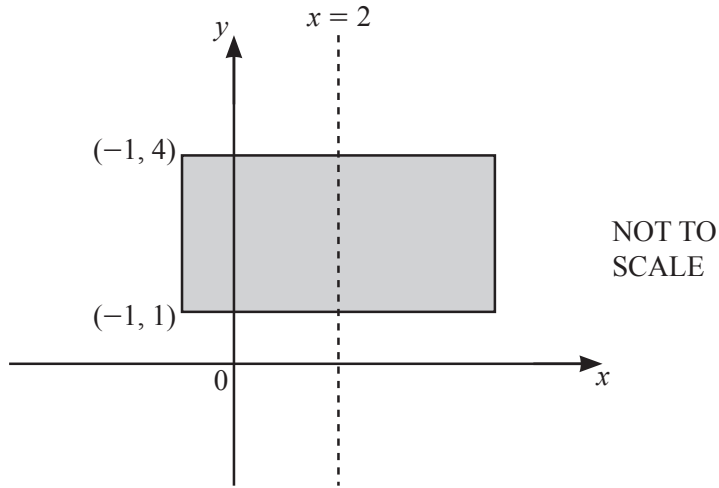

The diagram shows a rectangle with a line of symmetry at  $x = 2$ .  
Two vertices of the rectangle are at  $(-1, 1)$  and  $(-1, 4)$ .

The shaded region is defined by the inequalities  $a \leq x \leq b$  and  $c \leq y \leq d$ .

Find the values of  $a, b, c$  and  $d$ .

- $a = \dots\dots\dots$
- $b = \dots\dots\dots$
- $c = \dots\dots\dots$
- $d = \dots\dots\dots$  [2]

12 The interior angle of a regular polygon with  $n$  sides is  $156^\circ$ .

Work out the value of  $n$ .

$n = \dots\dots\dots$  [2]

13 Write the recurring decimal  $0.\dot{1}7$  as a fraction in its simplest form.  
You must show all your working.

$\dots\dots\dots$  [3]

14 Find the gradient of a line that is perpendicular to  $8y + 4x = 5$ .

..... [2]

15

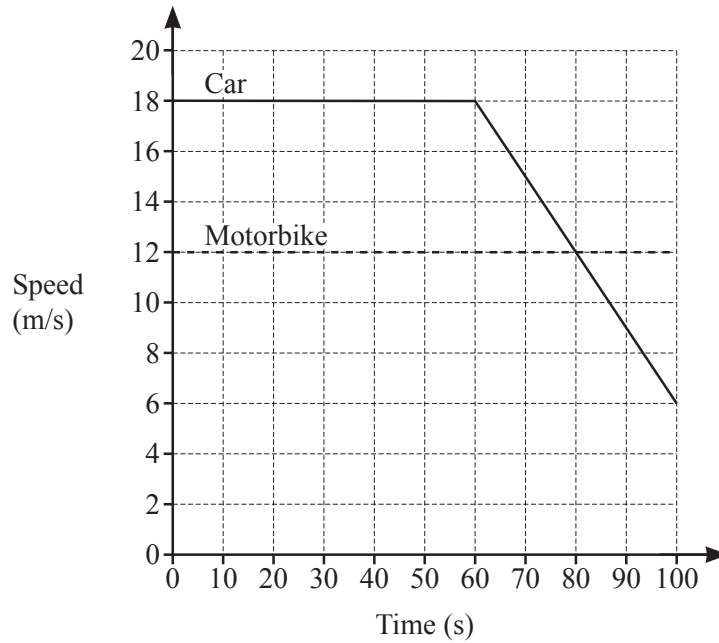

The diagram shows the speed–time graph for 100 seconds of the journey of a car and of a motorbike.

(a) Find the deceleration of the car between 60 and 100 seconds.

..... m/s<sup>2</sup> [1]

(b) Calculate how much further the car travelled than the motorbike during the 100 seconds.

..... m [3]

16 Factorise  $6x^2 + 7x - 20$ .

..... [2]

17 (a)  $f(x) = 3x^2 + a$  where  $a$  is an integer.  
 $f(-2) = 19$

Find the value of  $a$ .

$a =$  ..... [2]

(b)  $g(x) = 2x + 7$        $h(x) = 3x - 8$

(i) Find  $gh(x)$  in its simplest form.

..... [2]

(ii) Find  $g^{-1}(x)$ .

$g^{-1}(x) =$  ..... [2]



18

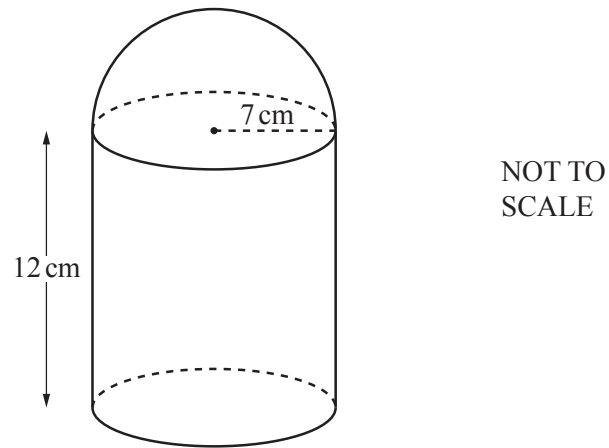

The diagram shows a solid made from a cylinder and a hemisphere, both of radius 7 cm. The cylinder has length 12 cm.

Work out the total surface area of the solid.

[The surface area,  $A$ , of a sphere with radius  $r$  is  $A = 4\pi r^2$ .]

..... cm<sup>2</sup> [4]

19 In this Venn diagram, shade the region  $M' \cup N \cup P$ .

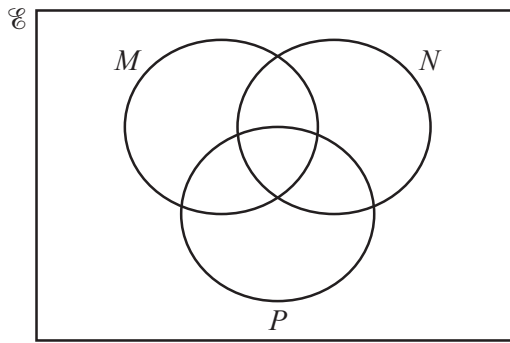

[1]

20

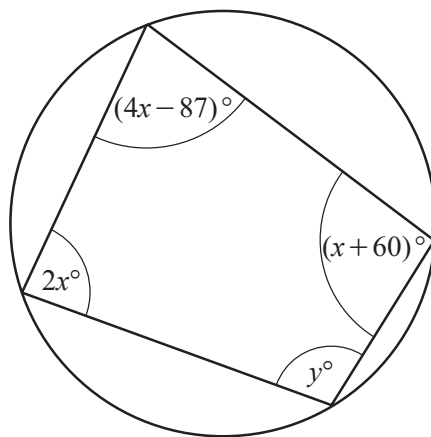

NOT TO SCALE

The diagram shows a cyclic quadrilateral.

Find the value of  $y$ .

$y = \dots\dots\dots$  [4]

21

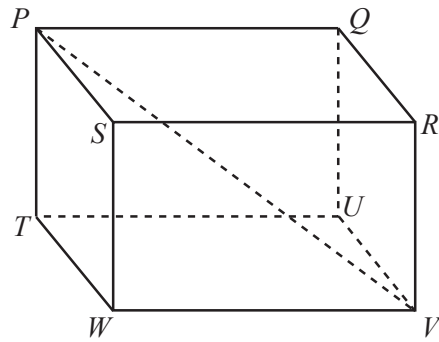

NOT TO SCALE

The diagram shows a cuboid  $PQRSTUWV$ .

$PV = 17.2$  cm

The angle between the line  $PV$  and the base  $TUVW$  of the cuboid is  $43^\circ$ .

Calculate  $PT$ .

$PT = \dots\dots\dots$  cm [3]

22 Simplify.

$$\frac{x^2 - 5x}{2x^2 - 50}$$

$\dots\dots\dots$  [4]

Question 23 is printed on the next page.

23 (a)

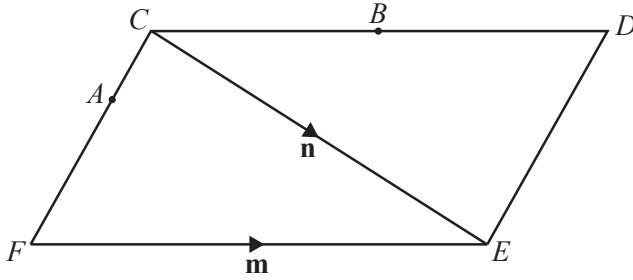

NOT TO SCALE

The diagram shows a parallelogram  $CDEF$ .

$\vec{FE} = \mathbf{m}$  and  $\vec{CE} = \mathbf{n}$ .

$B$  is the midpoint of  $CD$ .

$FA = 2AC$

Find an expression, in terms of  $\mathbf{m}$  and  $\mathbf{n}$ , for  $\vec{AB}$ .

Give your answer in its simplest form.

$\vec{AB} = \dots\dots\dots$  [3]

(b)  $\vec{GH} = \frac{5}{6}(2\mathbf{p} + \mathbf{q})$       $\vec{JK} = \frac{5}{18}(2\mathbf{p} + \mathbf{q})$

Write down **two** facts about vectors  $\vec{GH}$  and  $\vec{JK}$ .

.....  
 ..... [2]

Permission to reproduce items where third-party owned material protected by copyright is included has been sought and cleared where possible. Every reasonable effort has been made by the publisher (UCLES) to trace copyright holders, but if any items requiring clearance have unwittingly been included, the publisher will be pleased to make amends at the earliest possible opportunity.

To avoid the issue of disclosure of answer-related information to candidates, all copyright acknowledgements are reproduced online in the Cambridge Assessment International Education Copyright Acknowledgements Booklet. This is produced for each series of examinations and is freely available to download at [www.cambridgeinternational.org](http://www.cambridgeinternational.org) after the live examination series.

Cambridge Assessment International Education is part of the Cambridge Assessment Group. Cambridge Assessment is the brand name of the University of Cambridge Local Examinations Syndicate (UCLES), which itself is a department of the University of Cambridge.