



UNIVERSITY OF CAMBRIDGE INTERNATIONAL EXAMINATIONS
International General Certificate of Secondary Education

CO-ORDINATED SCIENCES

0654/13

Paper 1 Multiple Choice

October/November 2013

45 minutes

Additional Materials: Multiple Choice Answer Sheet
Soft clean eraser
Soft pencil (type B or HB is recommended)

* 5 4 4 0 9 4 1 4 1 6 7 *

READ THESE INSTRUCTIONS FIRST

Write in soft pencil.

Do not use staples, paper clips, highlighters, glue or correction fluid.

Write your name, Centre number and candidate number on the Answer Sheet in the spaces provided unless this has been done for you.

DO NOT WRITE IN ANY BARCODES.

There are **forty** questions on this paper. Answer **all** questions. For each question there are four possible answers **A, B, C** and **D**.

Choose the **one** you consider correct and record your choice in **soft pencil** on the separate Answer Sheet.

Read the instructions on the Answer Sheet very carefully.

Each correct answer will score one mark. A mark will not be deducted for a wrong answer.

Any rough working should be done in this booklet.

A copy of the Periodic Table is printed on page 20.

Electronic calculators may be used.

This document consists of **19** printed pages and **1** blank page.



- 1 A student was walking through some grass when he saw an object with a hole in its outer covering. When touched, a jet of fluid came out of the hole and the object moved away.

Which characteristics of living organisms has the object shown?

- A excretion, nutrition
 - B movement, respiration
 - C movement, sensitivity
 - D nutrition, sensitivity
- 2 The diagram shows the blood circulatory system of a human.

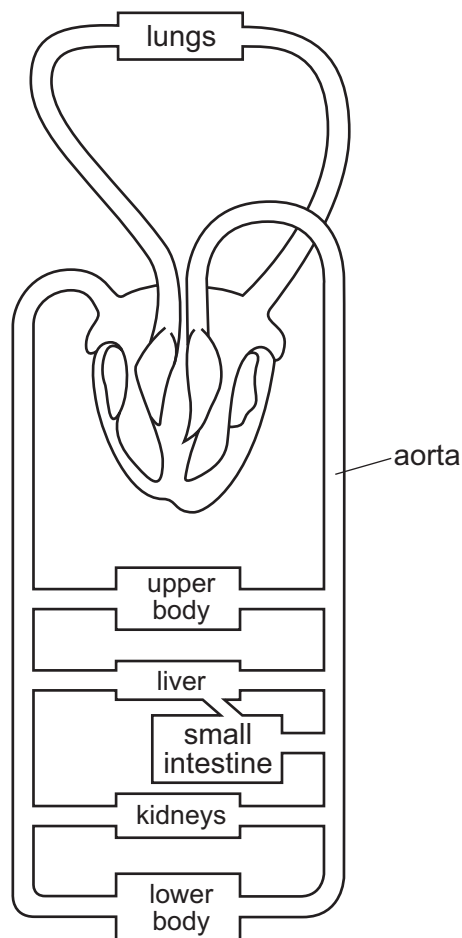

How many times must a blood cell pass through the heart on its way from the kidneys to the aorta?

- A once only
- B twice only
- C four times
- D more than four times

3 The diagrams show sections through a stem and a root.

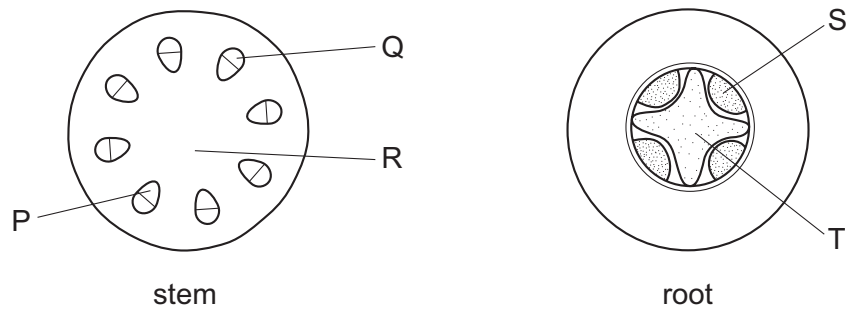

Which indicate the positions of the phloem?

- A** P and S **B** P and T **C** Q and S **D** R and T

4 The diagram shows the alimentary canal of a dog.

Where does egestion occur?

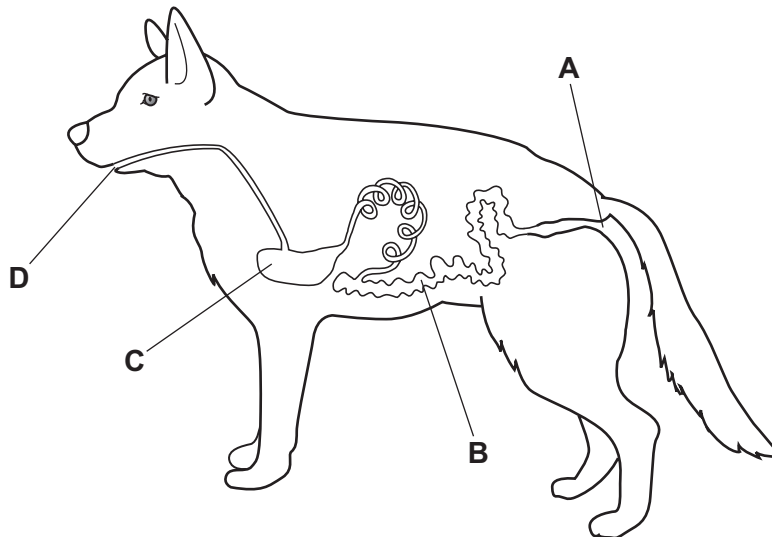

5 Which statement about asexual reproduction is correct?

- A** It involves the formation of a haploid zygote.
B It involves the fusion of haploid nuclei.
C It produces offspring that are genetically dissimilar to their parents.
D It produces offspring that are genetically identical to one another.

6 Which structures make up the nervous system?

- A brain, nerves, spinal cord
- B effectors, impulses, spinal cord
- C impulses, muscles, nerves
- D effectors, receptors, stimuli

7 The diagram shows an alveolus, a blood capillary and some red blood cells.

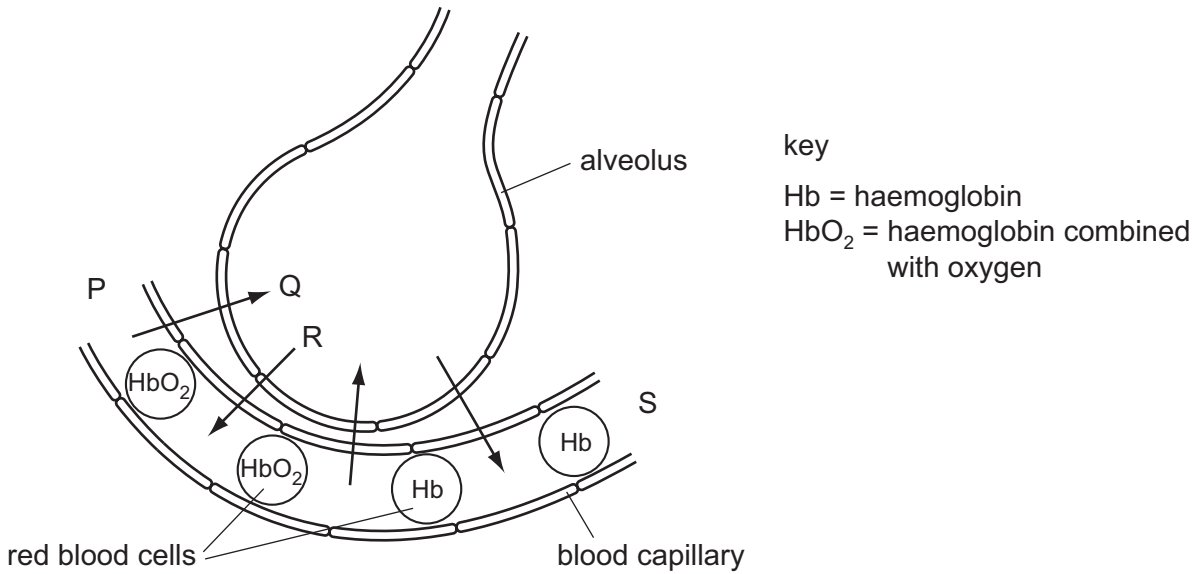

What is the direction of blood flow in the capillary and the direction of diffusion of oxygen?

	blood flow	oxygen diffusion
A	P to S	Q
B	P to S	R
C	S to P	Q
D	S to P	R

- 8 The diagram shows a nerve cell and associated structures.

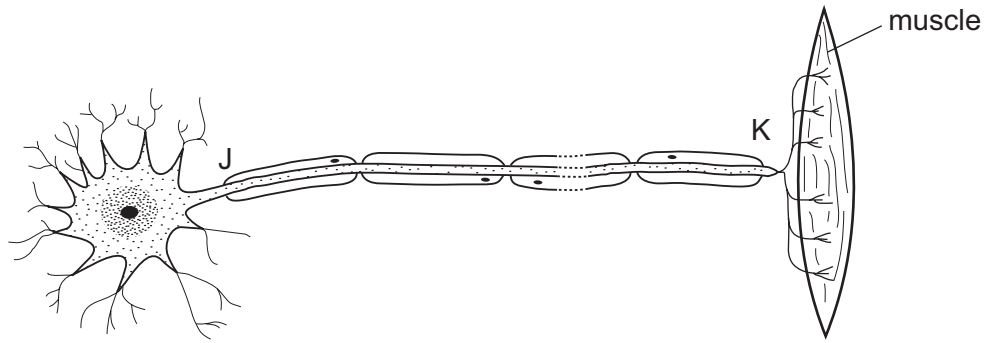

What type of nerve cell is it and in which direction do impulses travel?

	type of nerve cell	direction of impulse
A	motor	J to K
B	motor	K to J
C	sensory	J to K
D	sensory	K to J

- 9 The diagram shows a section through an insect-pollinated flower.

When pollination occurs where must the pollen grains reach?

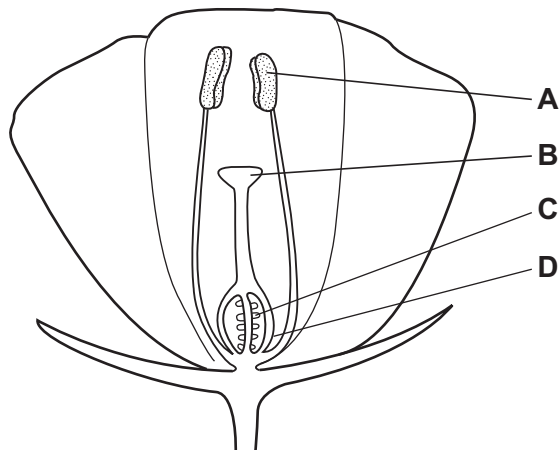

10 Seeds were placed on cotton wool in each of the tubes shown in the diagrams.

In which tube would germination start first?

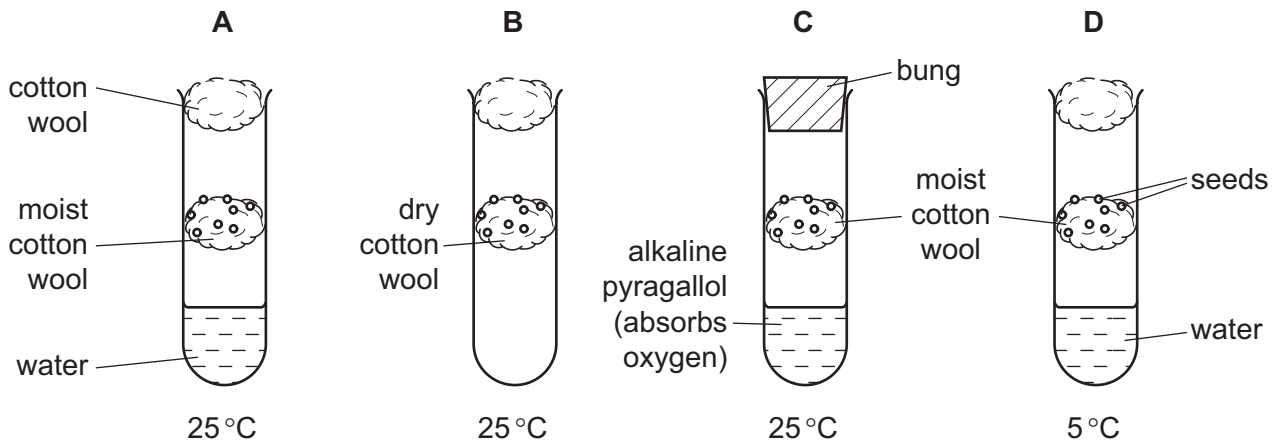

11 The alleles for a particular character are H and h.

Which term describes an organism whose genotype is HH?

- A heterozygous
- B homozygous
- C phenotype
- D recessive

12 Dung beetles lay their eggs in the faeces of plant-eating mammals like buffalo. Both the adult beetles and their young stages eat the **undigested** food in the faeces.

Which shows this food relationship?

- A buffalo → dung beetles
buffalo → grass
- B dung beetles → grass → buffalo
- C grass → dung beetles → buffalo
- D grass → buffalo
grass → dung beetles

- 13 The diagram shows part of the carbon cycle in a forest. The numbers represent different processes.

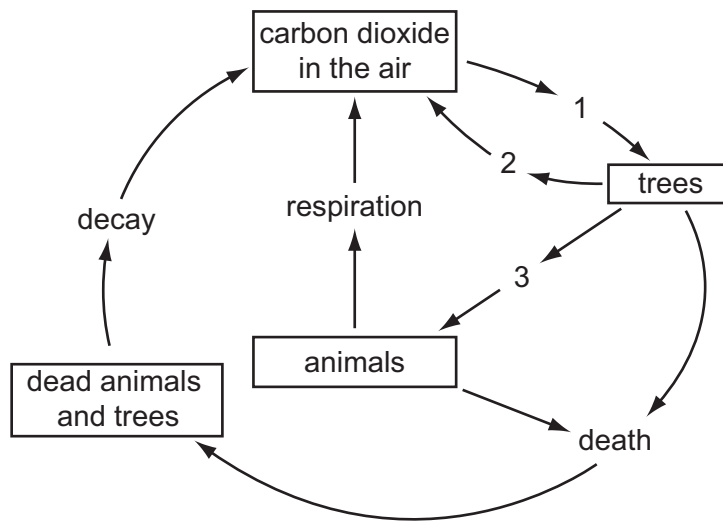

Which of these processes is reduced as a result of deforestation?

- A 1 only
 B 1 and 2 only
 C 2 and 3 only
 D 1, 2 and 3
- 14 Small amounts of barium chloride and sand are shaken with separate samples of water in two test-tubes. The test-tubes are left to stand for 24 hours.

Which diagram shows how the test-tubes appear at the end?

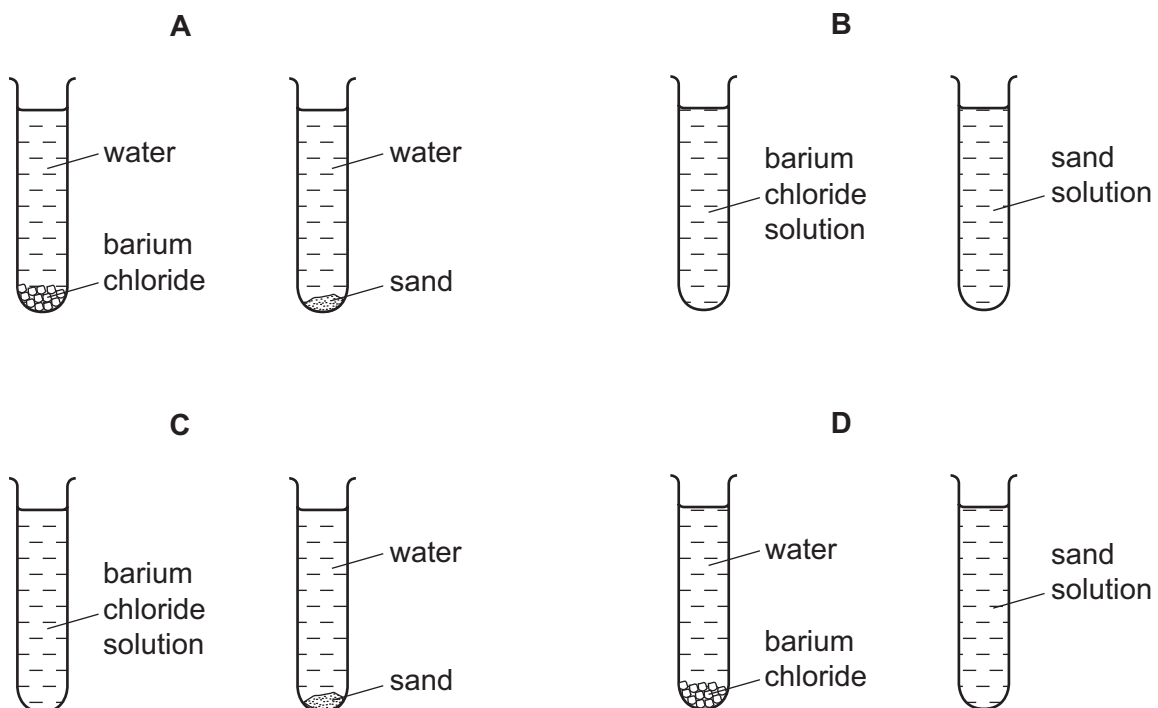

15 Which of the substances can conduct electricity?

	solid copper	molten copper	solid sodium chloride	molten sodium chloride
A	✓	✓	✓	✓
B	✓	✓	✗	✓
C	✗	✓	✓	✓
D	✗	✓	✗	✓

key

✓ = conduct

✗ = does not conduct

16 The diagram shows the energy change for the reactions between hydrogen and the halogens.

The size of the energy change is different for each halogen.

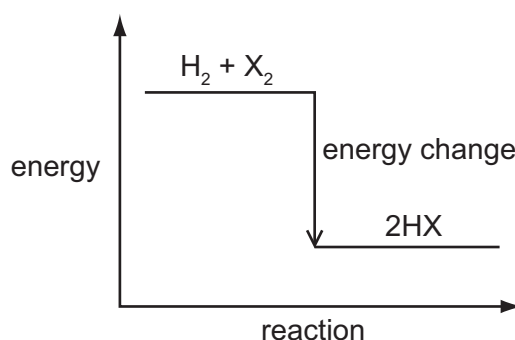

The reaction is $\text{H}_2 + \text{X}_2 \rightarrow 2\text{HX}$

The diagram shows that the reactions are1..... .

The most reactive halogen is2..... and therefore the energy change for this element is3..... .

Which words complete gaps 1, 2 and 3?

	1	2	3
A	endothermic	fluorine	least
B	endothermic	iodine	least
C	exothermic	fluorine	greatest
D	exothermic	iodine	greatest

17 The experiment shown is used to investigate the properties of solid X.

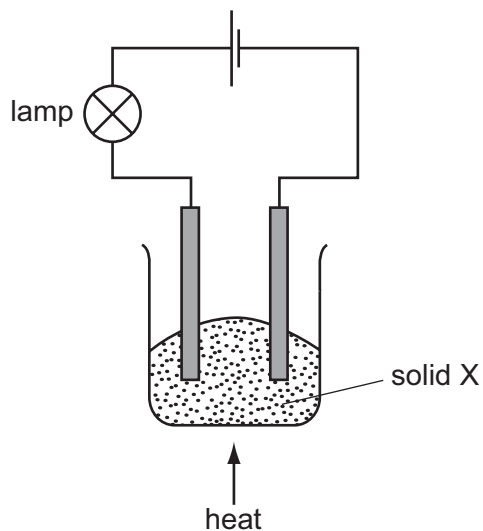

At first, the lamp does not light.

On heating, solid X melts and the lamp lights.

What type of substance is X?

- A a compound of a metal and a non-metal
- B a compound of two non-metals
- C a metallic element
- D a non-metallic element

18 The diagram shows apparatus used to investigate the speed of a reaction.

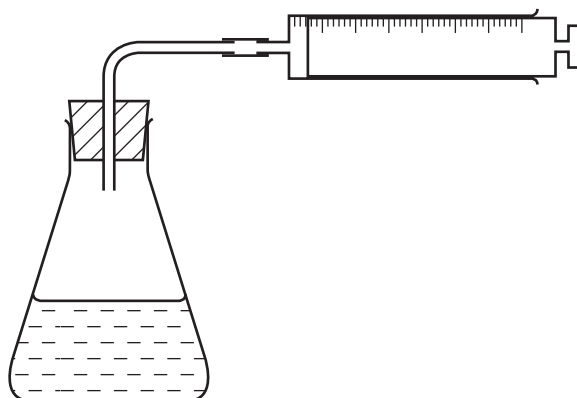

Which other item is essential for this investigation?

- A a Bunsen burner
- B a measuring cylinder
- C a stopclock
- D a thermometer

19 Brine is a mixture of salt (sodium chloride) and water.

Which row describes these substances?

	solute	solvent	solution
A	brine	salt	water
B	brine	water	salt
C	salt	brine	water
D	salt	water	brine

20 Substance X does not react with dilute acid. Substance Y reacts with dilute acid, forming a gas.

The graph shows the results of two experiments.

experiment 1 Y + dilute acid
experiment 2 X + Y + dilute acid

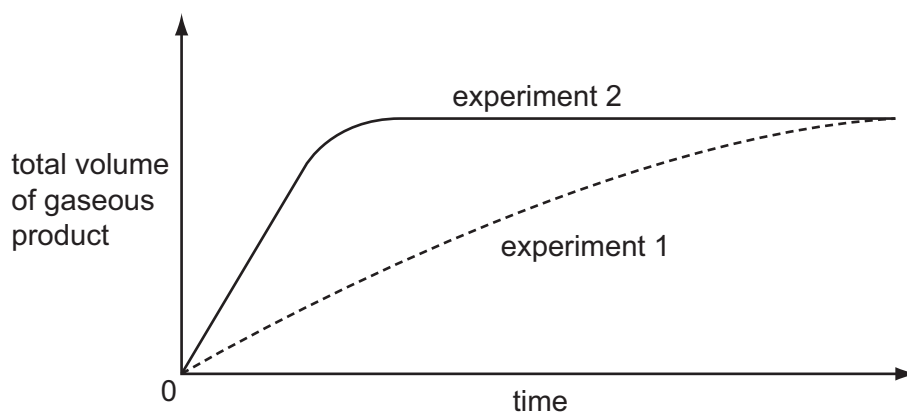

What do these results show?

	X is a catalyst	X is quickly used up	
A	✓	✓	key ✓ = true x = false
B	✓	x	
C	x	✓	
D	x	x	

21 The box shows four substances.

Br ₂	CO	Cu	Na
-----------------	----	----	----

Which substance is an element that forms a basic oxide and coloured compounds?

A Br₂ **B** CO **C** Cu **D** Na

22 A cup is made of copper.

Why is the cup **not** used for hot drinks?

- A Copper is a good conductor of heat.
- B Copper is a good electrical conductor.
- C Copper is brightly coloured.
- D Copper reacts with saliva.

23 An iron nail dissolves in an acid to form a salt solution.

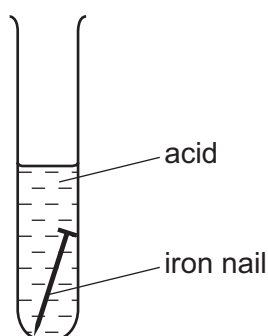

The salt solution forms a green precipitate with sodium hydroxide solution.

The salt solution also forms a white precipitate with barium chloride solution.

What is the salt solution?

- A iron(II) chloride
- B iron(III) chloride
- C iron(II) sulfate
- D iron(III) sulfate

24 Which type of reaction and which temperature change take place when an acid reacts with an alkali?

	type of reaction	temperature change
A	endothermic	decrease
B	endothermic	increase
C	exothermic	decrease
D	exothermic	increase

25 The elements in a Group of the Periodic Table are solid at 20 °C.

The reactivity of the elements increases down the group.

Which statements about this group of elements and their oxides are correct?

	the elements are in	their oxides are
A	Group I	acidic
B	Group I	basic
C	Group VII	acidic
D	Group VII	basic

26 In which experiment does limewater become milky?

A

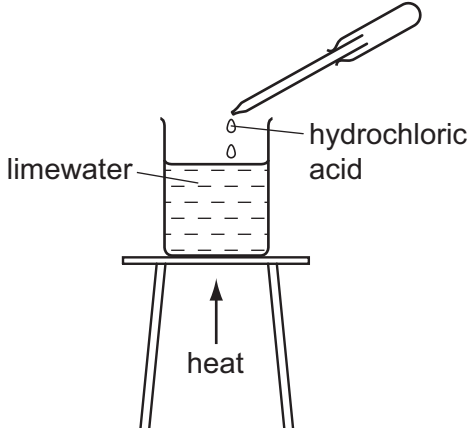

limewater

hydrochloric acid

heat

B

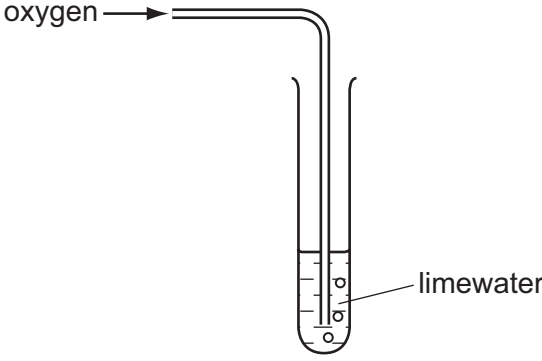

oxygen

limewater

C

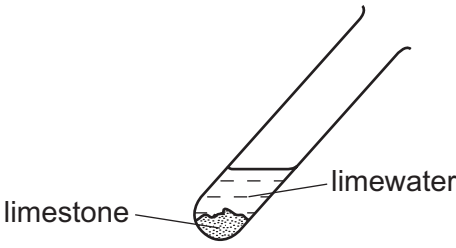

limewater

limestone

D

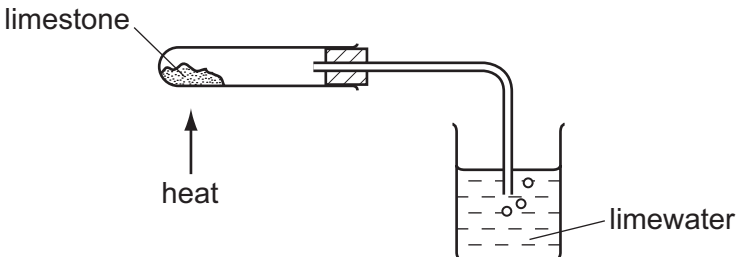

limestone

heat

limewater

29 The diagram shows the arrangement a student uses in an experiment.

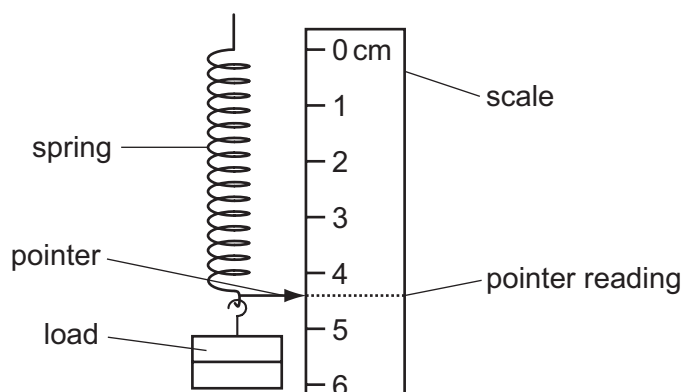

She writes down the steps in the order that she follows them, so that she can plot an extension/load graph for the spring.

Which step is **not** correct?

- A Each pointer reading is plotted against the corresponding load.
- B She subtracts the original length of the spring from each pointer reading.
- C The load is added in stages to the lower end of the spring.
- D The reading of the pointer against the scale is recorded for each different load.

30 A student writes an answer.

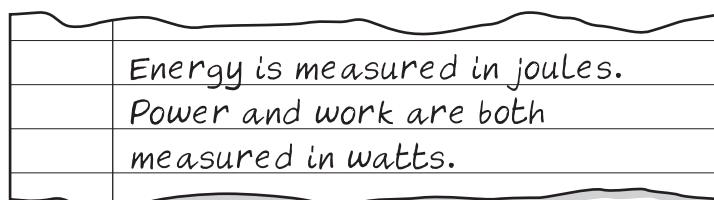

Why is this incorrect?

- A Energy is measured in watts.
- B Power is measured in joules.
- C Power is measured in newtons.
- D Work is measured in joules.

31 Liquid in a beaker evaporates quickly.

Which row shows what happens to the mass and to the temperature of the liquid in the beaker?

	mass	temperature
A	decreases	decreases
B	decreases	increases
C	increases	decreases
D	increases	increases

32 Two identical metal rods are 25 cm long at room temperature (20 °C).

One rod is put into a freezer at a temperature of -18°C . The other rod is put into an oven at a temperature of 200°C . The rods are left for several hours.

Which row shows the new length of each rod?

	length of rod at -18°C	length of rod at 200°C
A	25 cm	25 cm
B	25 cm	more than 25 cm
C	less than 25 cm	25 cm
D	less than 25 cm	more than 25 cm

33 The diagrams show part of a water-heating system which is working by convection.

Which diagram shows the flow of water in the system?

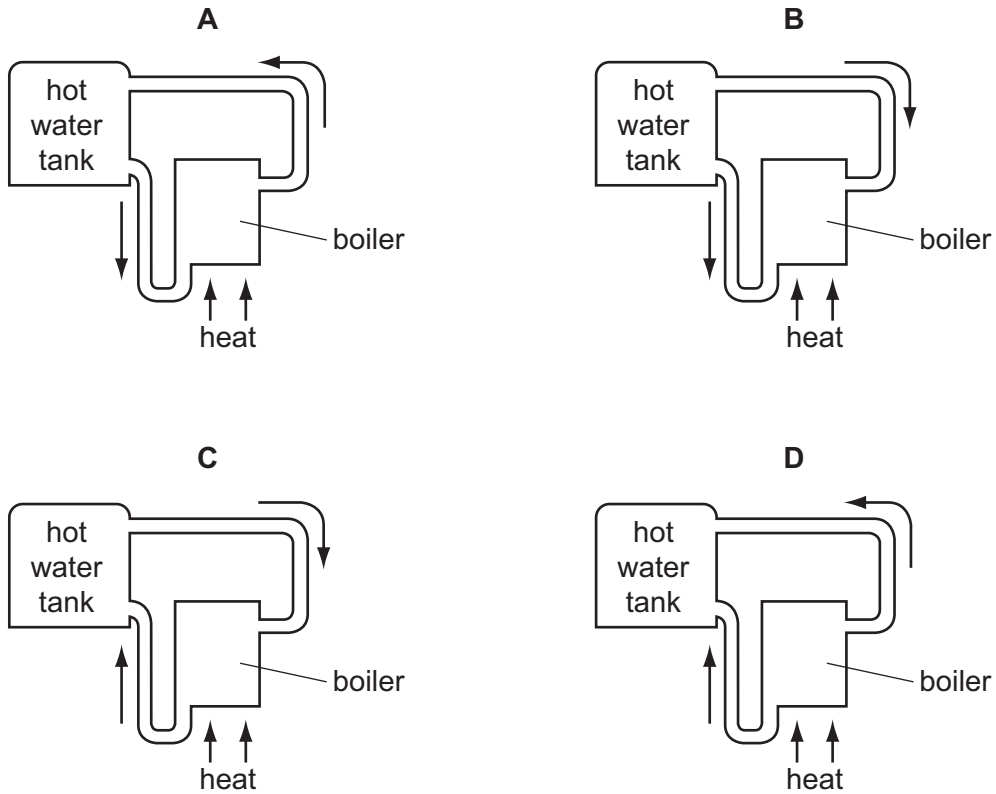

34 Which type of wave is longitudinal?

- A light wave
- B radio wave
- C sound wave
- D water wave

35 A plane mirror forms an image of an object placed in front of it.

Which row describes the image?

	image type	image size
A	real	same size as object
B	real	smaller than object
C	virtual	same size as object
D	virtual	smaller than object

36 Red light and violet light have different frequencies and different wavelengths.

Which colour light has the higher frequency and which has the larger wavelength?

	higher frequency	larger wavelength
A	red	red
B	red	violet
C	violet	red
D	violet	violet

37 What is the approximate value of the frequency of the highest-pitched sound that can be heard by a young person?

- A** 20 Hz **B** 200 Hz **C** 2000 Hz **D** 20 000 Hz

38 The circuit shows a current I in a resistor of resistance R .

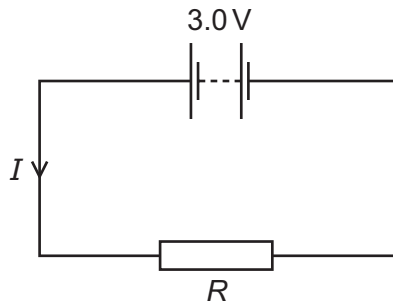

Which row gives possible values of I and of R ?

	I/A	R/Ω
A	1.5	1.5
B	1.5	2.0
C	6.0	2.0
D	4.0	12.0

- 39 Which row shows how lamps are connected in a domestic lighting circuit, and gives an advantage of connecting them in this way?

	how lamps are connected	advantage of connecting them in this way
A	in parallel	they can be switched separately
B	in parallel	they share the voltage
C	in series	they can be switched separately
D	in series	they share the voltage

- 40 An atom of beryllium is represented by ${}^9_4\text{Be}$.

How many neutrons are in the nucleus of this type of beryllium atom?

- A** 4 **B** 5 **C** 9 **D** 13

DATA SHEET
The Periodic Table of the Elements

		Group																																																																																																																						
		I	II	III	IV	V	VI	VII	VIII	IX	X																																																																																																													
		1 H Hydrogen 1																																																																																																																						
		4 He Helium 2																																																																																																																						
7	9	3	4	5	6	7	8	9	10	11	12	13	14	15	16	17	18	19	20																																																																																																					
Li Lithium	Be Beryllium	B Boron	C Carbon	N Nitrogen	O Oxygen	F Fluorine	Ne Neon	Na Sodium	Mg Magnesium	Al Aluminium	Si Silicon	P Phosphorus	S Sulfur	Cl Chlorine	Ar Argon	K Potassium	Ca Calcium	Sc Scandium	Ti Titanium	V Vanadium	Cr Chromium	Mn Manganese	Fe Iron	Co Cobalt	Ni Nickel	Cu Copper	Zn Zinc	Ga Gallium	Ge Germanium	As Arsenic	Se Selenium	Br Bromine	Kr Krypton																																																																																							
11	12	13	14	15	16	17	18	19	20	21	22	23	24	25	26	27	28	29	30	31	32	33	34	35	36	37	38	39	40	41	42	43	44	45	46	47	48	49	50	51	52	53	54																																																																													
Na Sodium	Mg Magnesium	Al Aluminium	Si Silicon	P Phosphorus	S Sulfur	Cl Chlorine	Ar Argon	K Potassium	Ca Calcium	Sc Scandium	Ti Titanium	V Vanadium	Cr Chromium	Mn Manganese	Fe Iron	Co Cobalt	Ni Nickel	Cu Copper	Zn Zinc	Ga Gallium	Ge Germanium	As Arsenic	Se Selenium	Br Bromine	Kr Krypton	Rb Rubidium	Sr Strontium	Y Yttrium	Zr Zirconium	Nb Niobium	Mo Molybdenum	Tc Technetium	Ru Ruthenium	Rh Rhodium	Pd Palladium	Ag Silver	Cd Cadmium	In Indium	Sn Tin	Sb Antimony	Te Tellurium	I Iodine	Xe Xenon																																																																													
41	42	43	44	45	46	47	48	49	50	51	52	53	54	55	56	57	58	59	60	61	62	63	64	65	66	67	68	69	70	71	72	73	74	75	76	77	78	79	80	81	82	83	84	85	86																																																																											
Rb Rubidium	Sr Strontium	Y Yttrium	Zr Zirconium	Nb Niobium	Mo Molybdenum	Tc Technetium	Ru Ruthenium	Rh Rhodium	Pd Palladium	Ag Silver	Cd Cadmium	In Indium	Sn Tin	Sb Antimony	Te Tellurium	I Iodine	Xe Xenon	Fr Francium	Ra Radium	Ac Actinium	Th Thorium	Pa Protactinium	U Uranium	Np Neptunium	Pu Plutonium	Am Americium	Cm Curium	Bk Berkelium	Cf Californium	Es Einsteinium	Fm Fermium	Md Mendelevium	No Nobelium	Lr Lawrencium																																																																																						
87	88	89	90	91	92	93	94	95	96	97	98	99	100	101	102	103	104	105	106	107	108	109	110	111	112	113	114	115	116	117	118	119	120	121	122	123	124	125	126	127	128	129	130	131	132	133	134	135	136	137	138	139	140	141	142	143	144	145	146	147	148	149	150	151	152	153	154	155	156	157	158	159	160	161	162	163	164	165	166	167	168	169	170	171	172	173	174	175																																
Fr Francium	Ra Radium	Ac Actinium	Th Thorium	Pa Protactinium	U Uranium	Np Neptunium	Pu Plutonium	Am Americium	Cm Curium	Bk Berkelium	Cf Californium	Es Einsteinium	Fm Fermium	Md Mendelevium	No Nobelium	Lr Lawrencium																																																																																																								
133	134	135	136	137	138	139	140	141	142	143	144	145	146	147	148	149	150	151	152	153	154	155	156	157	158	159	160	161	162	163	164	165	166	167	168	169	170	171	172	173	174	175																																																																														
Cs Caesium	Ba Barium	La Lanthanum	Ce Cerium	Pr Praseodymium	Nd Neodymium	Pm Promethium	Sm Samarium	Eu Europium	Gd Gadolinium	Tb Terbium	Dy Dysprosium	Ho Holmium	Er Erbium	Tm Thulium	Yb Ytterbium	Lu Lutetium																																																																																																								
55	56	57	58	59	60	61	62	63	64	65	66	67	68	69	70	71	72	73	74	75	76	77	78	79	80	81	82	83	84	85	86	87	88	89	90	91	92	93	94	95	96	97	98	99	100	101	102	103	104	105	106	107	108	109	110	111	112	113	114	115	116	117	118	119	120	121	122	123	124	125	126	127	128	129	130	131	132	133	134	135	136	137	138	139	140	141	142	143	144	145	146	147	148	149	150	151	152	153	154	155	156	157	158	159	160	161	162	163	164	165	166	167	168	169	170	171	172	173	174	175
Fr Francium	Ra Radium	La Lanthanum	Ce Cerium	Pr Praseodymium	Nd Neodymium	Pm Promethium	Sm Samarium	Eu Europium	Gd Gadolinium	Tb Terbium	Dy Dysprosium	Ho Holmium	Er Erbium	Tm Thulium	Yb Ytterbium	Lu Lutetium																																																																																																								
87	88	89	90	91	92	93	94	95	96	97	98	99	100	101	102	103	104	105	106	107	108	109	110	111	112	113	114	115	116	117	118	119	120	121	122	123	124	125	126	127	128	129	130	131	132	133	134	135	136	137	138	139	140	141	142	143	144	145	146	147	148	149	150	151	152	153	154	155	156	157	158	159	160	161	162	163	164	165	166	167	168	169	170	171	172	173	174	175																																
Fr Francium	Ra Radium	Ac Actinium	Th Thorium	Pa Protactinium	U Uranium	Np Neptunium	Pu Plutonium	Am Americium	Cm Curium	Bk Berkelium	Cf Californium	Es Einsteinium	Fm Fermium	Md Mendelevium	No Nobelium	Lr Lawrencium																																																																																																								
87	88	89	90	91	92	93	94	95	96	97	98	99	100	101	102	103	104	105	106	107	108	109	110	111	112	113	114	115	116	117	118	119	120	121	122	123	124	125	126	127	128	129	130	131	132	133	134	135	136	137	138	139	140	141	142	143	144	145	146	147	148	149	150	151	152	153	154	155	156	157	158	159	160	161	162	163	164	165	166	167	168	169	170	171	172	173	174	175																																
Fr Francium	Ra Radium	Ac Actinium	Th Thorium	Pa Protactinium	U Uranium	Np Neptunium	Pu Plutonium	Am Americium	Cm Curium	Bk Berkelium	Cf Californium	Es Einsteinium	Fm Fermium	Md Mendelevium	No Nobelium	Lr Lawrencium																																																																																																								
87	88	89	90	91	92	93	94	95	96	97	98	99	100	101	102	103	104	105	106	107	108	109	110	111	112	113	114	115	116	117	118	119	120	121	122	123	124	125	126	127	128	129	130	131	132	133	134	135	136	137	138	139	140	141	142	143	144	145	146	147	148	149	150	151	152	153	154	155	156	157	158	159	160	161	162	163	164	165	166	167	168	169	170	171	172	173	174	175																																
Fr Francium	Ra Radium	Ac Actinium	Th Thorium	Pa Protactinium	U Uranium	Np Neptunium	Pu Plutonium	Am Americium	Cm Curium	Bk Berkelium	Cf Californium	Es Einsteinium	Fm Fermium	Md Mendelevium	No Nobelium	Lr Lawrencium																																																																																																								
87	88	89	90	91	92	93	94	95	96	97	98	99	100	101	102	103	104	105	106	107	108	109	110	111	112	113	114	115	116	117	118	119	120	121	122	123	124	125	126	127	128	129	130	131	132	133	134	135	136	137	138	139	140	141	142	143	144	145	146	147	148	149	150	151	152	153	154	155	156	157	158	159	160	161	162	163	164	165	166	167	168	169	170	171	172	173	174	175																																
Fr Francium	Ra Radium	Ac Actinium	Th Thorium	Pa Protactinium	U Uranium	Np Neptunium	Pu Plutonium	Am Americium	Cm Curium	Bk Berkelium	Cf Californium	Es Einsteinium	Fm Fermium	Md Mendelevium	No Nobelium	Lr Lawrencium																																																																																																								
87	88	89	90	91	92	93	94	95	96	97	98	99	100	101	102	103	104	105	106	107	108	109	110	111	112	113	114	115	116	117	118	119	120	121	122	123	124	125	126	127	128	129	130	131	132	133	134	135	136	137	138	139	140	141	142	143	144	145	146	147	148	149	150	151	152	153	154	155	156	157	158	159	160	161	162	163	164	165	166	167	168	169	170	171	172	173	174	175																																
Fr Francium	Ra Radium	Ac Actinium	Th Thorium	Pa Protactinium	U Uranium	Np Neptunium	Pu Plutonium	Am Americium	Cm Curium	Bk Berkelium	Cf Californium	Es Einsteinium	Fm Fermium	Md Mendelevium	No Nobelium	Lr Lawrencium																																																																																																								
87	88	89	90	91	92	93	94	95	96	97	98	99	100	101	102	103	104	105	106	107	108	109	110	111	112	113	114	115	116	117	118	119	120	121	122	123	124	125	126	127	128	129	130	131	132	133	134	135	136	137	138	139	140	141	142	143	144	145	146	147	148	149	150	151	152	153																																																						