



UNIVERSITY OF CAMBRIDGE INTERNATIONAL EXAMINATIONS
International General Certificate of Secondary Education

CANDIDATE
NAME

CENTRE
NUMBER

--	--	--	--	--

CANDIDATE
NUMBER

--	--	--	--



PHYSICS

0625/61

Paper 6 Alternative to Practical

May/June 2013

1 hour

Candidates answer on the Question Paper.

No Additional Materials are required.

READ THESE INSTRUCTIONS FIRST

Write your Centre number, candidate number and name on all the work you hand in.

Write in dark blue or black pen.

You may use a pencil for any diagrams or graphs.

Do not use staples, paper clips, highlighters, glue or correction fluid.

DO NOT WRITE IN ANY BARCODES.

Answer **all** questions.

Electronic calculators may be used.

You may lose marks if you do not show your working or if you do not use appropriate units.

At the end of the examination, fasten all your work securely together.

The number of marks is given in brackets [] at the end of each question or part question.

For Examiner's Use	
1	
2	
3	
4	
5	
Total	

This document consists of **11** printed pages and **1** blank page.



- 1 The IGCSE class is investigating the stability of a block of wood.

Figs. 1.1 and 1.2 show the dimensions of the block.

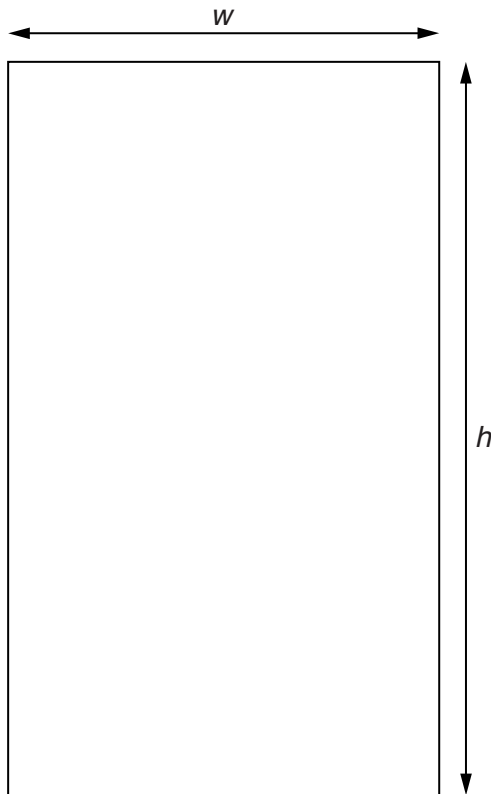

Fig. 1.1

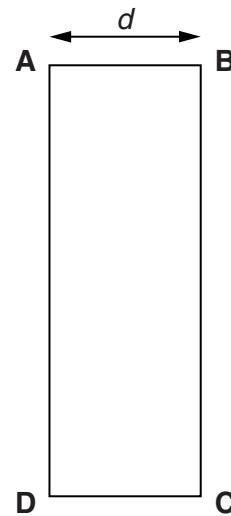

Fig. 1.2

- (a) (i) On Figs. 1.1 and 1.2, measure the height h , width w and depth d of the block.

$h =$

$w =$

$d =$

[2]

- (ii) On Fig. 1.2, draw the line **AC**.

[1]

- (iii) Measure and record the angle α between lines **AD** and **AC**.

$\alpha =$ [1]

(b) A student places the block on the edge of the bench, as shown in Fig. 1.3.

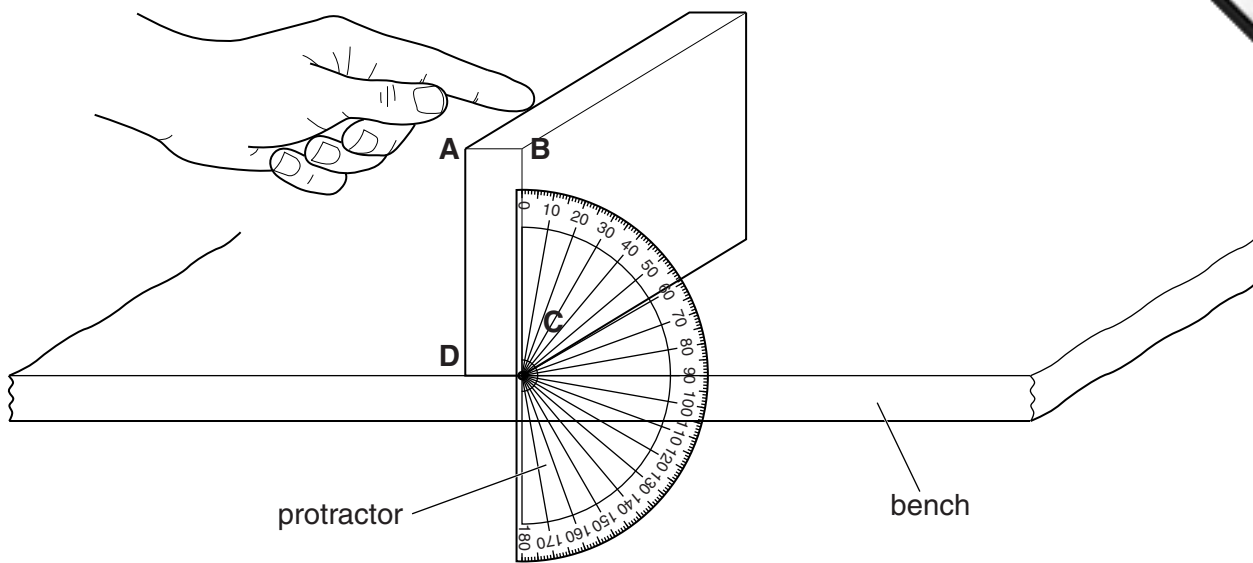

Fig. 1.3

He holds the protractor next to face **ABCD** of the block, as shown in Fig. 1.3. He gently pushes the top of the block (as indicated in Fig. 1.3) so that the block tips over.

He records the angle θ between side **BC** of the block and the vertical line on the protractor. The angle θ is when the block just tips over. He repeats this procedure a suitable number of times.

Suggest the number of measurements of θ that you think would be suitable for this experiment.

number =[1]

(c) The student calculates the average value θ_{av} of all his values for θ .

$\theta_{av} = \dots\dots\dots 20^\circ \dots\dots\dots$

He suggests that θ_{av} should be equal to α . State whether the results support this suggestion. Justify your statement by reference to the results.

statement

justification

.....

.....

[2]

[Total: 7]

2 The IGCSE class is investigating the scale of a thermometer.

(a) Record room temperature θ_R as shown on the thermometer in Fig. 2.1.

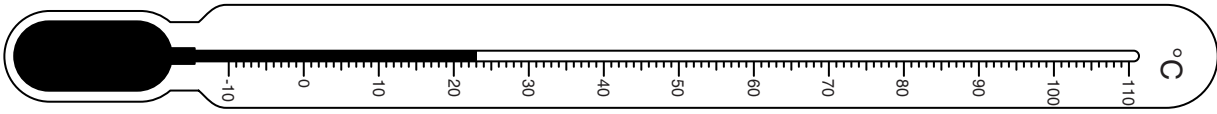

Fig. 2.1

$$\theta_R = \dots\dots\dots [1]$$

A student pours hot water into a beaker. She measures the temperature θ of the water in the beaker every 30 s. The readings are shown in Table 2.1.

Table 2.1

$t/$	$\theta/$	$d/$
0	80	
30	74	
60	69	
90	65	
120	63	
150	61	
180	60	

(b) (i) Using Fig. 2.2, measure, and record in the table, the distance d from the end of the thermometer to the position of the liquid in the thermometer at the first temperature reading in the table.

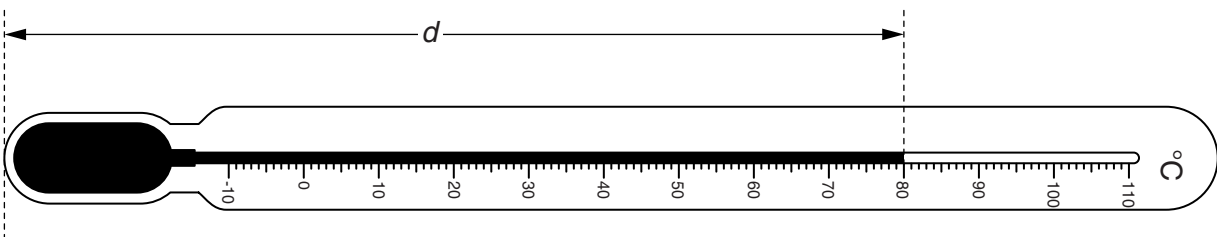

Fig. 2.2

(ii) Repeat the measurement in (b)(i) for all the other temperature readings. [2]

(iii) Complete the column headings in the table. [1]

(c) The student plotted a graph of θ against d . A sketch of the graph obtained is shown in Fig. 2.3.

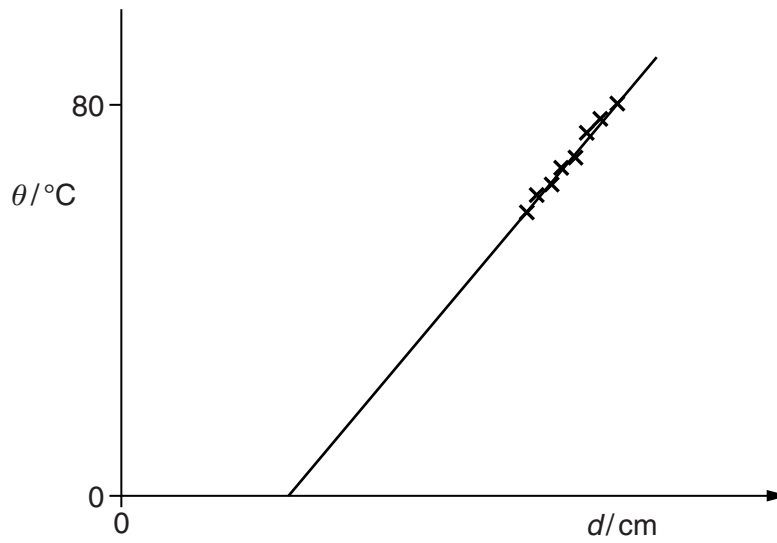

Fig. 2.3

(i) Explain how the graph line shows that θ is not directly proportional to d .

.....
 [1]

(ii) Suggest why, when $\theta = 0^\circ\text{C}$, the value of d is not zero.

.....

 [1]

(d) Determine, as accurately as possible, the distance x between the 1°C marks on the thermometer shown in Fig. 2.2. Show your working.

$x =$ [3]

[Total: 9]

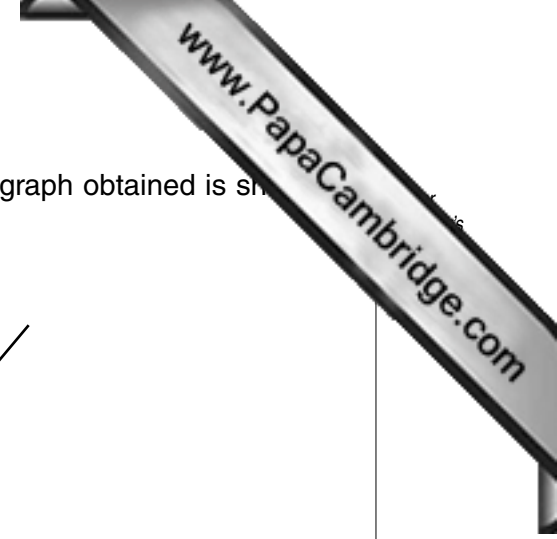

- 3 The IGCSE class is investigating the resistance of a wire.

The circuit used is shown in Fig. 3.1.

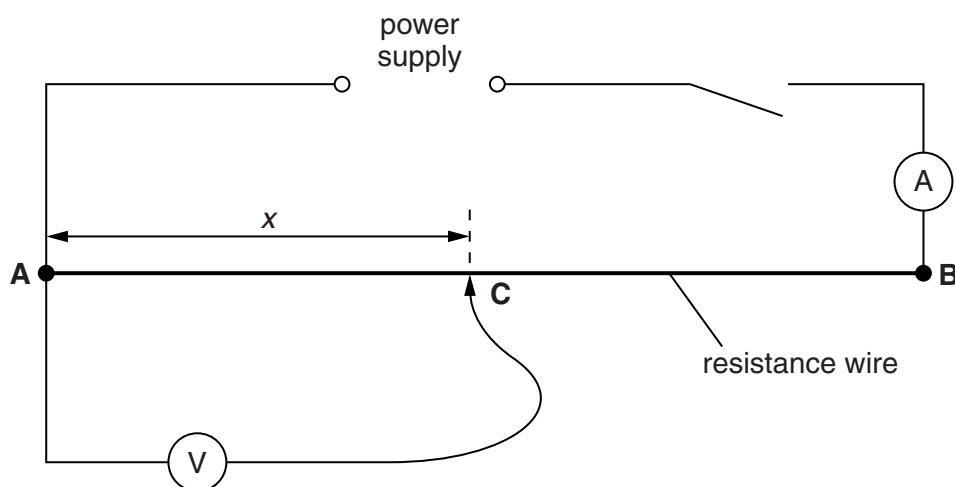

Fig. 3.1

A student moves contact **C** to give a range of values of the length x . For each length x , the current I and potential difference V are measured and recorded in Table 3.1.

- (a) (i) Calculate the resistance R of 10.0 cm of the resistance wire using the equation $R = \frac{V}{I}$. Record this value of R in the table.
- (ii) Repeat step (i) for each of the other values of x .
- (iii) Complete the column headings in the table.

Table 3.1

$x/$	$V/$	$I/$	$R/$
10.0	0.20	0.33	
30.0	0.60	0.33	
50.0	1.01	0.32	
70.0	1.41	0.33	
90.0	1.81	0.33	

[3]

(b) Plot a graph of V/V (y -axis) against R/Ω (x -axis).

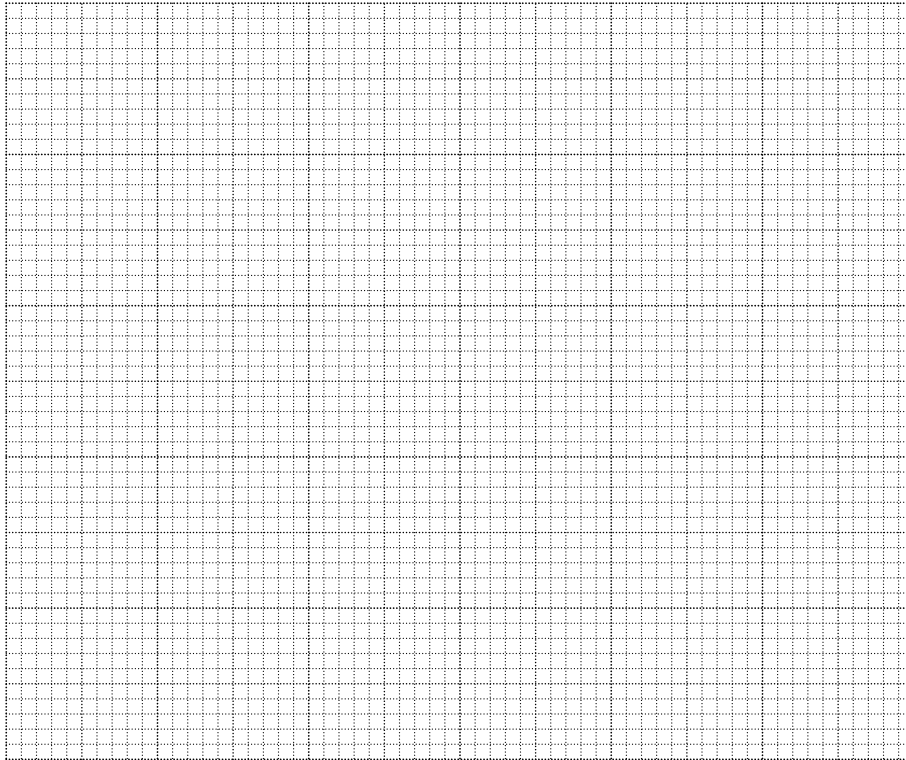

[5]

(c) Determine the gradient G of the graph. Show clearly on the graph how you obtained the necessary information.

$G = \dots\dots\dots$ [3]

[Total: 11]

4 The IGCSE class is investigating the position of the image in a plane mirror.

A student's ray-trace sheet is shown in Fig. 4.1.

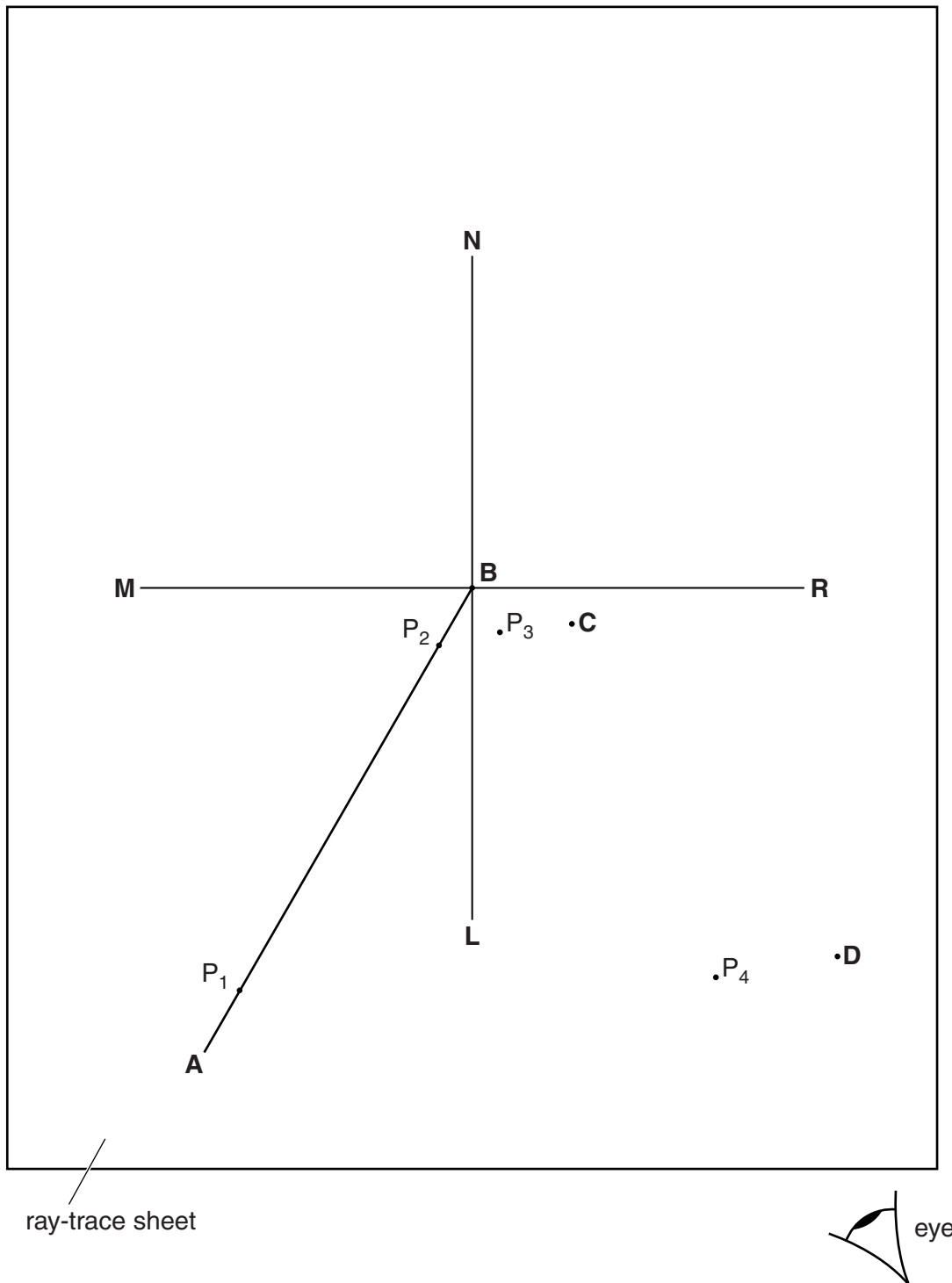

Fig. 4.1

The line **MR** shows the position of a plane mirror. **NL** is the normal at the centre of the mirror.

AB marks the position of an incident ray.

The student pushes two pins, P_1 and P_2 into this line. She views the images of pins P_1 and P_2 from the direction indicated by the eye in Fig. 4.1.

She places two pins P_3 and P_4 some distance apart so that pins P_4 and P_3 , and the images of P_2 and of P_1 , all appear exactly one behind the other. The positions of P_3 and P_4 are labelled.

(a) Draw in the line joining the positions of P_3 and P_4 . Continue the line until it crosses **MR** and extends at least 8.0 cm beyond **MR**. [1]

(b) The student repeats the procedure without moving pin P_1 but using a different angle of incidence. On Fig. 4.1, the new positions of pins P_3 and P_4 are marked **C** and **D**.

(i) Draw in the line joining the positions **C** and **D**. Continue the line until it extends at least 8.0 cm beyond **MR**.

(ii) Label with a **Y** the point where the two lines beyond **MR** cross. [1]

(c) (i) Draw a line from P_1 to **MR** that meets **MR** at a right angle. Measure and record the length a of this line.

$a =$

(ii) Draw a line from the point labelled **Y** to **MR** that meets **MR** at a right angle. Measure and record the length b of this line.

$b =$

[2]

(d) A student suggests that the length of a should equal the length of b .

State whether your results support this suggestion. Justify your statement by reference to your results.

statement

justification

.....

.....

[2]

(e) Suggest a precaution that you would take, when placing the pins, in order to obtain reliable results.

.....

..... [1]

[Total: 7]

5 The IGCSE class is determining the mass of a load **X** using a balancing method.

Fig. 5.1 shows the apparatus.

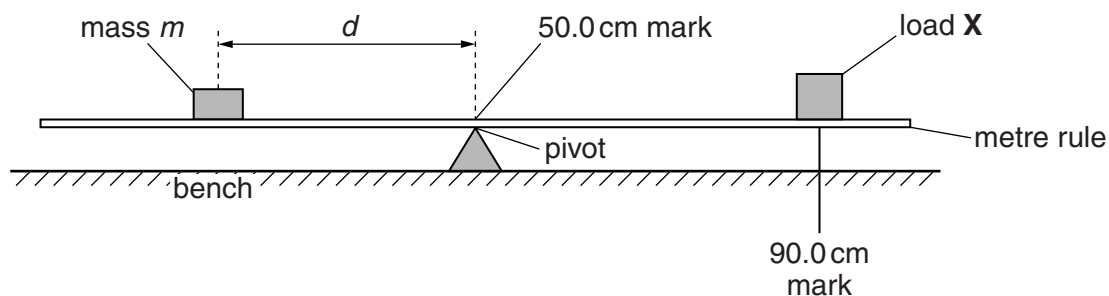

Fig. 5.1

The centre of the load **X** is fixed at the 90.0 cm mark on the rule.

A student uses a range of values of the mass *m* and determines the distance *d* from the pivot where the mass must be placed to balance the rule. The readings are shown in Table 5.1.

Table 5.1

<i>m/g</i>	<i>d/cm</i>
40	30.2
50	23.9
60	20.0
70	17.1
80	15.1

(a) Calculate the distance *x* between the centre of the load **X** and the centre of the rule.

$x = \dots\dots\dots [1]$

(b) Suggest a reason for the student using a range of *m* values.

.....

 [1]

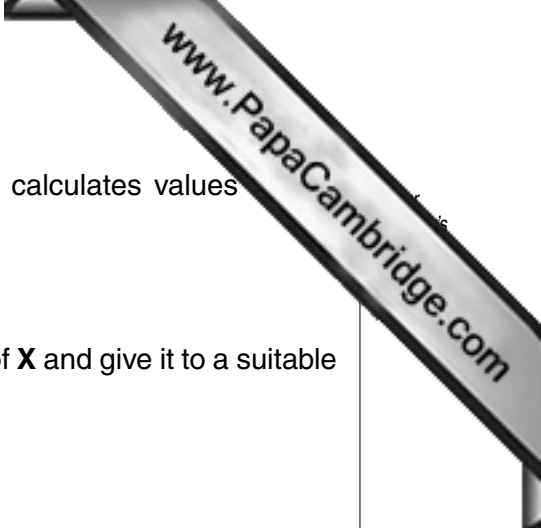

- (c) Using each set of readings and the value of x , the student calculates values for the mass of the load **X**.

He writes his results: 30.2 g, 29.875 g, 30 g, 29.925 g, 30.2 g.

Use these results to calculate an average value for the mass of **X** and give it to a suitable number of significant figures for this type of experiment.

average value for the mass of **X** =[2]

- (d) This type of balancing experiment is difficult to carry out.

Suggest one practical difficulty and one way to try to overcome the difficulty. You may draw a diagram, if you wish.

practical difficulty

.....

.....

way to overcome the difficulty

.....

.....

[2]

[Total: 6]

Permission to reproduce items where third-party owned material protected by copyright is included has been sought and cleared where possible. Every reasonable effort has been made by the publisher (UCLES) to trace copyright holders, but if any items requiring clearance have unwittingly been included, the publisher will be pleased to make amends at the earliest possible opportunity.

University of Cambridge International Examinations is part of the Cambridge Assessment Group. Cambridge Assessment is the brand name of University of Cambridge Local Examinations Syndicate (UCLES), which is itself a department of the University of Cambridge.

© UCLES 2013