



*Rewarding Learning*

ADVANCED  
General Certificate of Education  
2017

Centre Number

--	--	--	--	--

Candidate Number

--	--	--	--	--

---

## Physics

Assessment Unit A2 3  
Practical Techniques  
Session 1

**MV18**

[AY231]

**TUESDAY 9 MAY, MORNING**

---

### **Time**

1 hour 30 minutes, plus your additional time allowance.

### **Instructions to Candidates**

Write your Centre Number and Candidate Number in the spaces provided at the top of this page.

Turn to page 2 for further Instructions and Information.

## **Instructions to Candidates**

Answer **all** questions in this paper. Rough work and calculations must also be done in this paper. Except where instructed, do not describe the apparatus or experimental procedures. The supervisor will tell you the order in which you are to answer the questions. Not more than 30 minutes are to be spent in answering each question. You may be told to start with the experimental tests in Section A, or with the single question in Section B.

Section A consists of two experimental tests. A 28-minute period is allocated for you to use the apparatus. Two minutes is allocated to the supervisor to prepare the station for the next candidate. At the end of the 30-minute period you will be instructed to move to the area set aside for your next question. Section B consists of one question in which you will be tested on aspects of planning and design.

## **Information for Candidates**

The total mark for this paper is 60.

All questions carry 20 marks each.

Figures in brackets printed at the end of each question indicate the marks awarded to each part question.

You may use an electronic calculator.

## Section A

- 1 The angle through which a light ray deviates after refraction through a triangular prism depends on the refractive index of the prism and the incident angle. The angle of deviation,  $D$ , is the angle between the incident ray and the emergent ray, see **Fig. 1.1**.

### Aims:

- To measure values of the angle of deviation for different angles of incidence,
- To draw a graph of angle of deviation against angle of incidence,
- To find a value for the refractive index between the media.

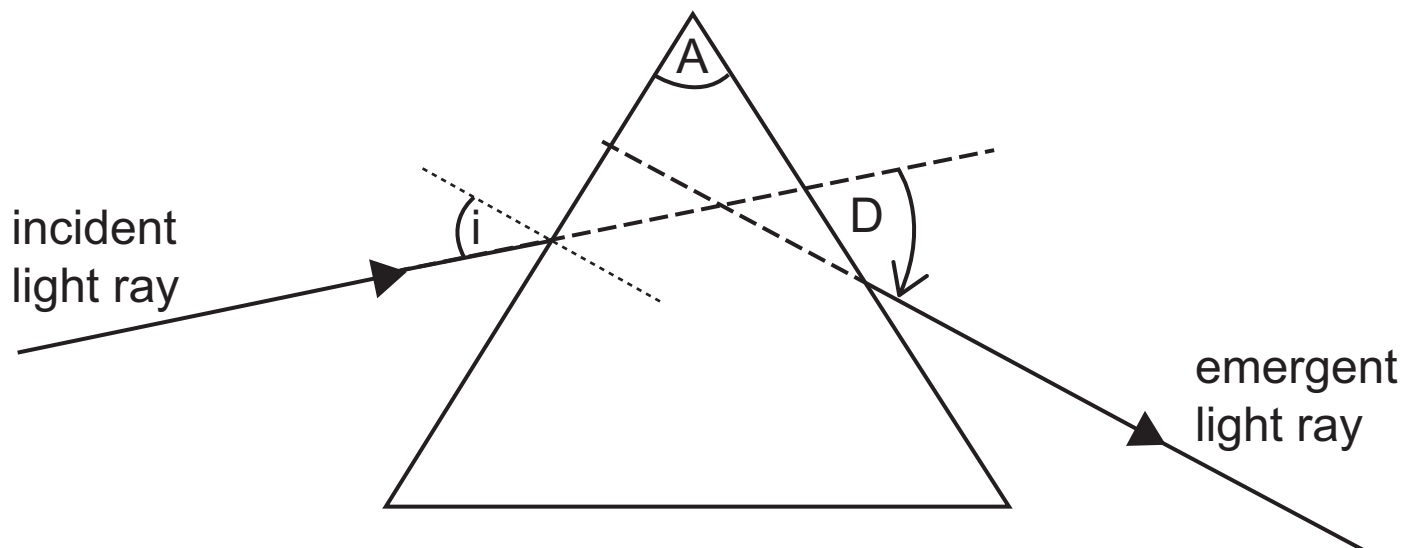

**Fig. 1.1**

(a) Carefully position the top of the prism in the position indicated.

Direct the incident light ray along the paths indicated and for each diagram in **Fig. 1.2** accurately mark the position of the emerging light ray from the right-hand side of the prism. [2 marks]

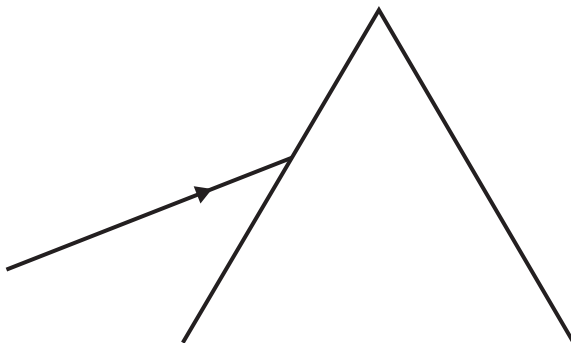
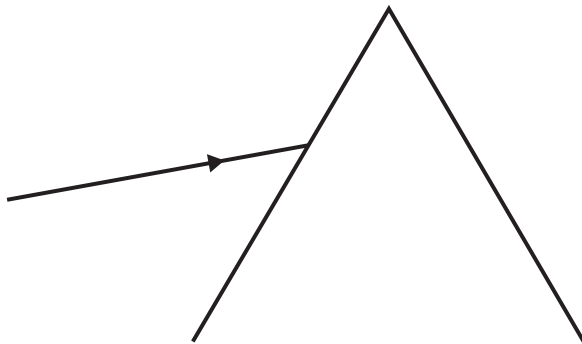
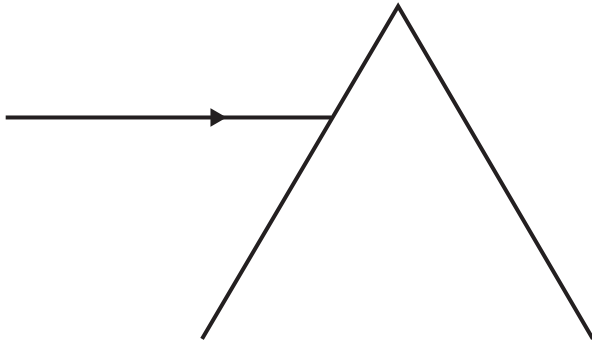

**Fig. 1.2** continues on page 5 opposite

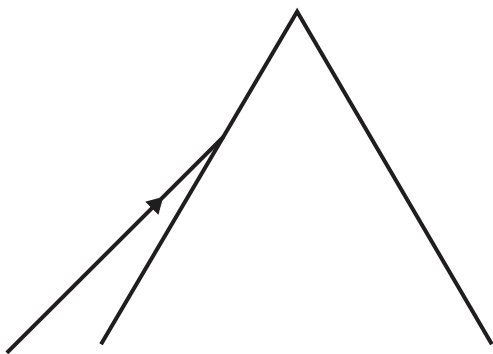
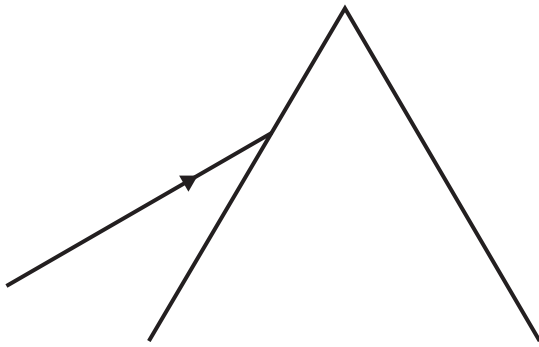

**Fig. 1.2**

**(b)** Complete each diagram by using a ruler to

**(i)** draw the path taken by the emergent ray and

**(ii)** extend the incident and emergent rays until they meet

as shown in **Fig. 1.1**. [1 mark]

- (c) Complete **Table 1.1** by inserting the value of the angle of incidence,  $i$ , and the corresponding angle of deviation,  $D$ , for each diagram. [5 marks]

**Table 1.1**

$i / ^\circ$					
$D / ^\circ$					

- (d) (i) On the grid of **Fig. 1.3** opposite draw the graph, angle of deviation against angle of incidence. Plot the points and draw a best fit curve. [4 marks]
- (ii) Use the best fit curve on **Fig. 1.3** to determine the minimum angle of deviation,  $D_{\min}$ , for the triangular prism. [1 mark]

$$D_{\min} = \underline{\hspace{4cm}}^\circ$$

- (iii) Determine the angle of incidence,  $i$ , at which  $D_{\min}$  occurs. [1 mark]

$$i = \underline{\hspace{4cm}}^\circ$$

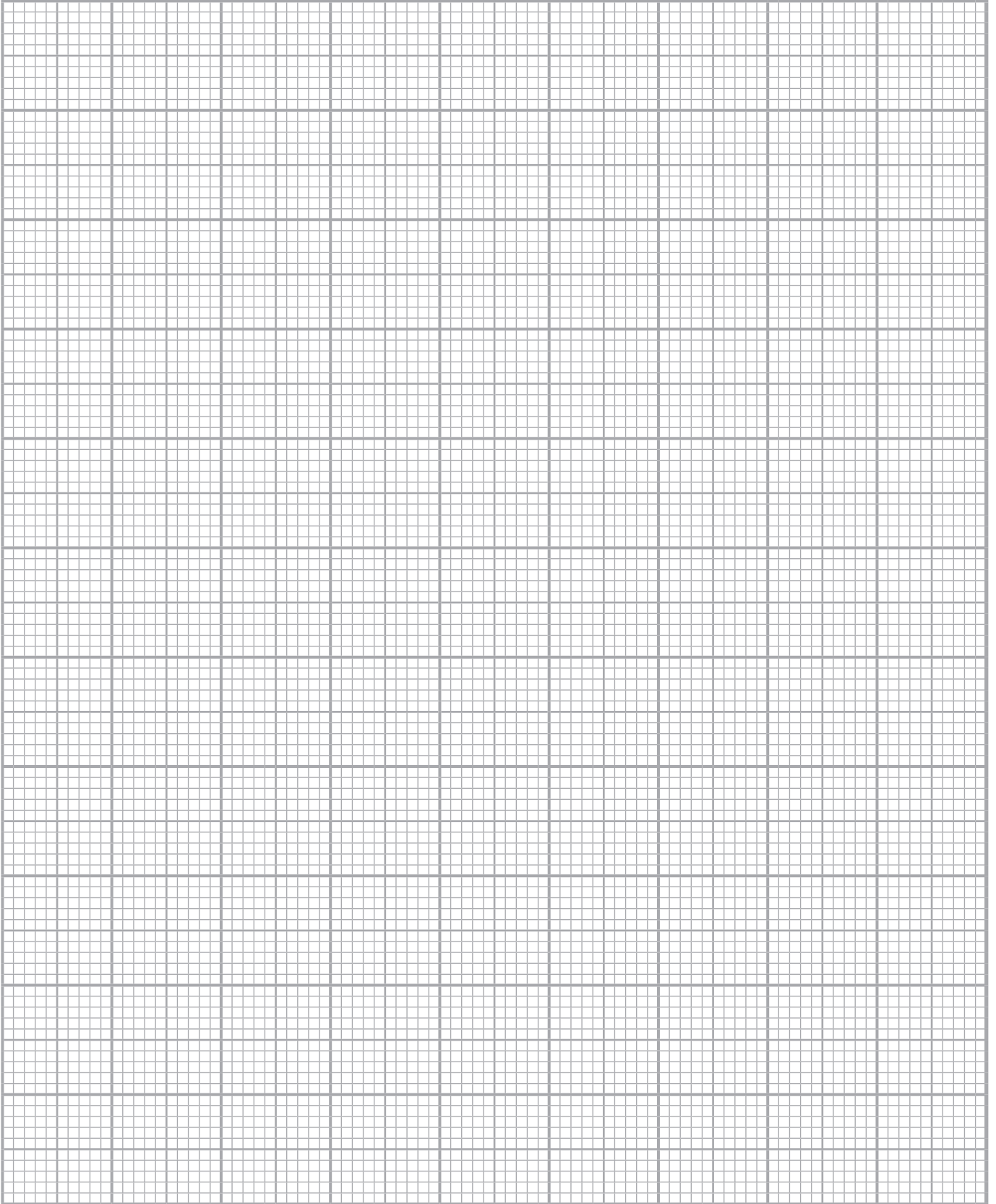

**Fig. 1.3**

- (e) The refractive index,  $n$ , of the material from which the triangular prism is made can be calculated using **Equation 1.1**.

$$n = \frac{\sin\left(\frac{A + D_{\min}}{2}\right)}{\sin\left(\frac{A}{2}\right)}$$

**Equation 1.1**

where  $A$  is the apex angle of the prism.

- (i) Measure the apex angle,  $A$ , of the prism. [1 mark]  
See **Fig. 1.1** on page 3.

$A =$  \_\_\_\_\_ °

- (ii) Use **Equation 1.1** to calculate the refractive index of the material from which the prism is made.  
[2 marks]

$n =$  \_\_\_\_\_



(iii) Take the uncertainty in angle  $A$  as  $\pm 1^\circ$  and the uncertainty in  $D_{\min}$  as  $\pm 2^\circ$ . Determine the maximum value of the refractive index of the material from which the prism is made and hence determine the absolute uncertainty,  $\Delta n$ , in the refractive index.  
[3 marks]

$$n_{\max} = \underline{\hspace{10em}}$$

$$\Delta n = \pm \underline{\hspace{10em}}$$

**BLANK PAGE**

- 2 The opposition to alternating current caused by a capacitor is called the reactance. The reactance,  $X$ , is defined as the ratio of the alternating potential difference,  $V$ , across the capacitor to the alternating current,  $I$ , through it: that is,  $X = V/I$ . In this experiment you will measure the reactance of a capacitor, at various frequencies. Reactance is measured in ohm,  $\Omega$ .

The aims of the experiment are:

- to obtain values of the alternating current through and alternating voltage across a capacitor,
- to calculate the reactance of the capacitor at various frequencies,
- to analyse the results and compare them with a theoretical relationship between reactance and frequency.

### Obtaining values of alternating current and alternating voltage

You are provided with the circuit shown in **Fig. 2.1**.

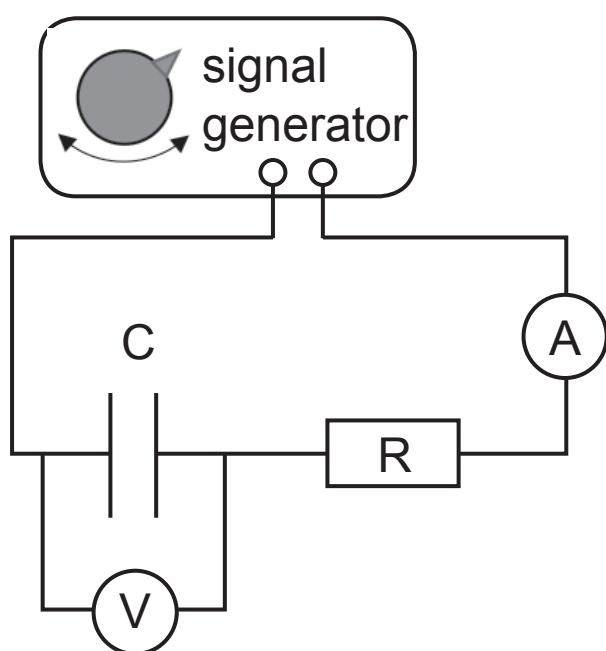

**Fig. 2.1**

(a) Set the signal generator frequency,  $f$ , to 10 Hz. Record the readings on the voltmeter and ammeter in **Table 2.1**.

Adjust the frequency to 30 Hz and repeat the procedure.

Repeat the procedure until you have five sets of readings in the frequency range 10 Hz to 90 Hz.

[3 marks]

**Table 2.1**

$f / \text{Hz}$	$V / \text{mV}$	$I / \text{mA}$	$X / \Omega$		

### Calculating reactance

At a given frequency, the reactance  $X$  of the capacitor is given by

$$X = \frac{V}{I}$$

### Equation 2.1

(b) Use **Equation 2.1** to calculate the value of  $X$  at each frequency listed in **Table 2.1** and record the values of  $X$  in **Table 2.1**. [2 marks]

## Analysis

The theoretical relationship between reactance and frequency  $f$  is given by

$$X = kf^n$$

### Equation 2.2

where  $k$  and  $n$  are constants.

- (c) (i) Determine the logarithm to base 10 for each frequency and insert the value, to 2 decimal places, into **Table 2.1** opposite. Head the column appropriately.  
[2 marks]
- (ii) Determine the logarithm to base 10 for each reactance and insert the value, to 2 decimal places, into **Table 2.1** opposite. Head the column appropriately.  
[2 marks]
- (iii) Label the axes of the graph grid in **Fig. 2.2** overleaf with the logarithm to base 10 of frequency on the  $x$  axis and the logarithm to base 10 of reactance on the  $y$  axis. Choose suitable scales, plot the points and draw the best fit straight line. [4 marks]

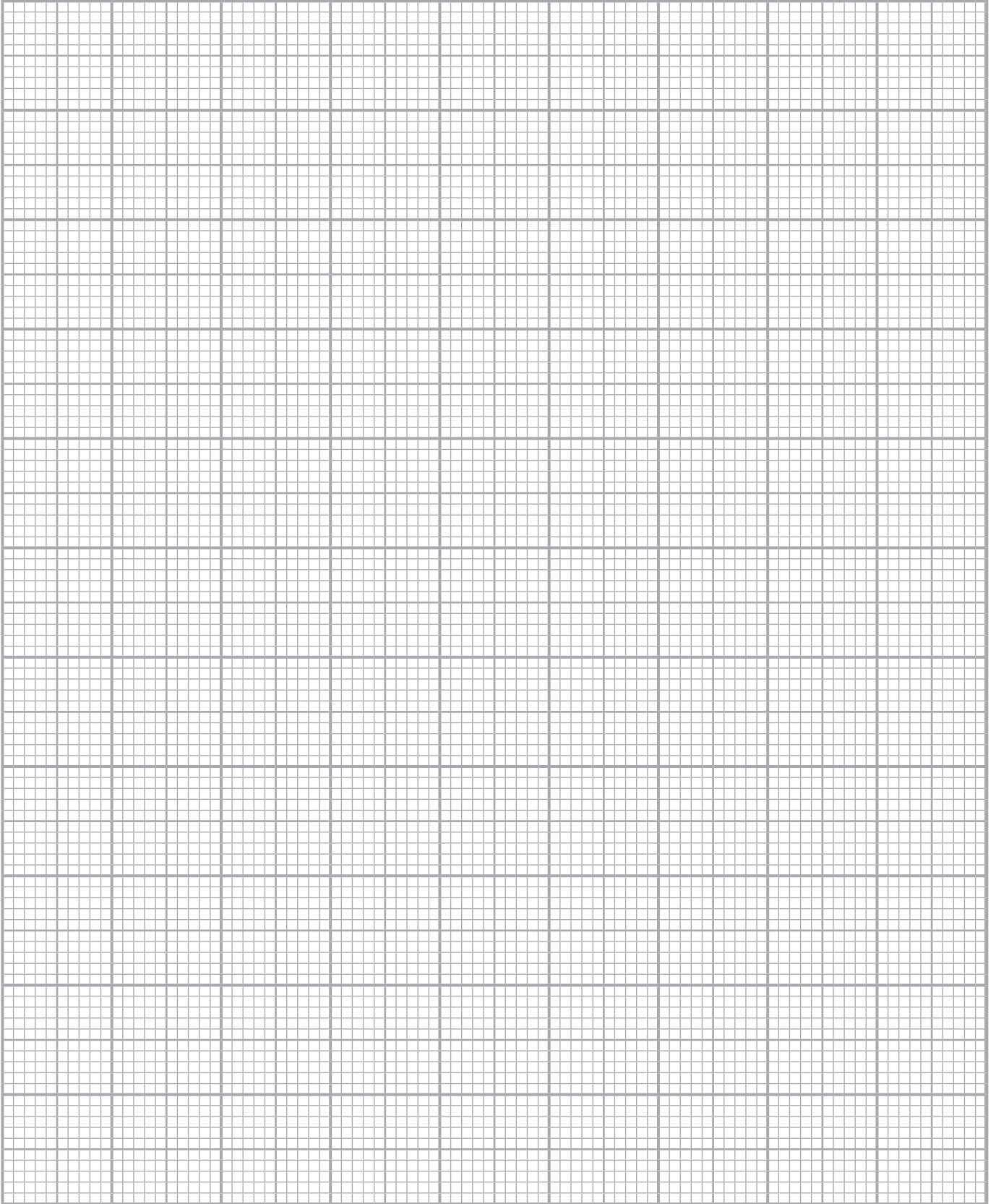

**Fig. 2.2**

- (d) (i) Determine the gradient of the best fit line in **Fig. 2.2**.  
Give your answer to two significant figures.  
[2 marks]

Gradient = \_\_\_\_\_

- (ii) Determine the intercept on the vertical axis of the graph in **Fig. 2.2**. [2 marks]

Intercept = \_\_\_\_\_

Constant  $k$  in **Equation 2.2** is related to capacitance  $C$  by

$$K = \frac{1}{2\pi C}$$

**Equation 2.3**

(iii) Determine the capacitance in the circuit. [3 marks]

$$C = \underline{\hspace{10em}} \text{ F}$$



**BLANK PAGE**

**(Questions continue overleaf)**

## Section B

- 3 In this question you are to investigate how the energy stored in a stretched spring depends on the extension of the spring.

The spring has been mounted so that it can easily be stretched as shown in **Fig. 3.1**. The spring has been attached to the piston at position A and to a rigid box at position B. The spring is stretched by pulling the piston to the left.

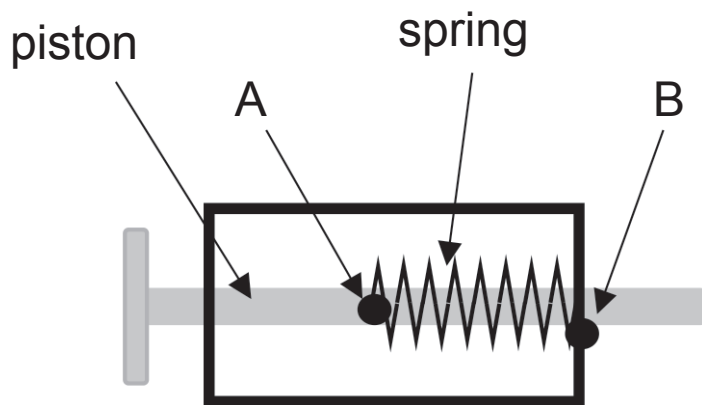

**Fig. 3.1**

It has been suggested that the energy stored in the spring can be determined using a ramp. A ball bearing is projected by the piston up a ramp at an angle  $\theta$  to the horizontal, as shown in **Fig. 3.2**.

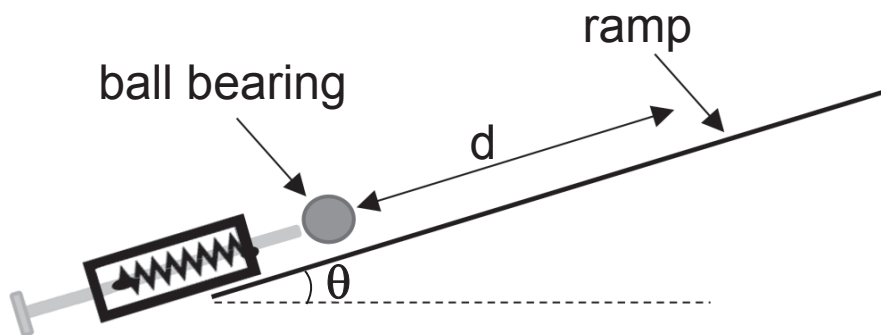

**Fig. 3.2**

When the piston is released the ball bearing travels up the ramp, a distance  $d$ , before coming momentarily to rest.

**(a) Determining the energy stored in the stretched spring.**

Using the conservation of energy principle, derive an equation that links the energy,  $E$ , stored in the stretched spring to the distance,  $d$ . Identify any other symbols you use. [3 marks]

$E =$  \_\_\_\_\_

**(b) Determining the relationship between d and spring extension, x.**

In (a) E was linked to d, but E depends on the extension, x, of the spring and as a consequence x and d are related. The relationship between x and d is shown in **Equation 3.1**.

$$x^2 = Ad + Z$$

**Equation 3.1**

where A and Z are positive constants.

- (i)** A linear graph can be drawn to show if **Equation 3.1** is correct. On **Fig. 3.3** label the axes for this graph. Sketch the graph you would expect to obtain. [2 marks]



**Fig. 3.3**

- (ii) A results table is required to record sufficient **reliable** data that would allow **Equation 3.1** to be verified by drawing the graph shown in **(b)(i)**.

Draw out a suitable table showing all rows and columns required. Clearly label the headings of each column. Include suitable units for each heading.  
[5 marks]

- (iii) Name the significant **variables** that have to be controlled in this experiment. [3 marks]

---

---

---

---

- (iv) How could a value of A be obtained from these results? [1 mark]

---

---

---

**(c) Obtaining additional data from which the spring constant can be determined.**

The value of constant A in **Equation 3.1** is given by **Equation 3.2**.

$$A = \frac{2mg \sin\theta}{k}$$

**Equation 3.2**

where m is the mass of the ball bearing,  
g is the acceleration of free fall and  
k is the spring constant.

**(i)** Outline the procedures to be used and the measuring instruments required to determine values for d, x, m and  $\theta$ . [3 marks]

---

---

---

---

---

---

---

---

---

---

---

- (ii) Explain how the percentage uncertainty in  $A$  is determined and describe how it is used to obtain a value for the percentage uncertainty in  $k$ .  
[3 marks]

---

---

---

---

---

---

---

---

---

---

---

---

---

**THIS IS THE END OF THE QUESTION PAPER**

---

For Examiner's use only		
Question Number	Marks	Remark
1		
2		
3		
<b>Total Marks</b>		

Permission to reproduce all copyright material has been applied for.  
 In some cases, efforts to contact copyright holders may have been unsuccessful and CCEA will be happy to rectify any omissions of acknowledgement in future if notified.