

**Tuesday 13 June 2017 – Morning**

**GCSE METHODS IN MATHEMATICS**

**B391/02** Methods in Mathematics 1 (Higher Tier)

Candidates answer on the Question Paper.

**OCR supplied materials:**

None

**Other materials required:**

- Geometrical instruments
- Tracing paper (optional)

**Duration:** 1 hour 15 minutes

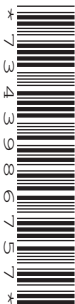

|                    |  |                   |  |
|--------------------|--|-------------------|--|
| Candidate forename |  | Candidate surname |  |
|--------------------|--|-------------------|--|

|               |  |  |  |  |  |                  |  |  |  |  |
|---------------|--|--|--|--|--|------------------|--|--|--|--|
| Centre number |  |  |  |  |  | Candidate number |  |  |  |  |
|---------------|--|--|--|--|--|------------------|--|--|--|--|

**INSTRUCTIONS TO CANDIDATES**

- Write your name, centre number and candidate number in the boxes above. Please write clearly and in capital letters.
- Use black ink. HB pencil may be used for graphs and diagrams only.
- Answer **all** the questions.
- Read each question carefully. Make sure you know what you have to do before starting your answer.
- Write your answer to each question in the space provided. If additional space is required, you should use the lined page(s) at the end of this booklet. The question number(s) must be clearly shown.
- Do **not** write in the barcodes.

**INFORMATION FOR CANDIDATES**

- The number of marks is given in brackets [ ] at the end of each question or part question.
- Quality of written communication will be assessed in questions marked with an asterisk (\*).
- The total number of marks for this paper is **60**.
- This document consists of **16** pages. Any blank pages are indicated.

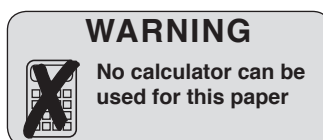

## Formulae Sheet: Higher Tier

**Area of trapezium** =  $\frac{1}{2}(a + b)h$

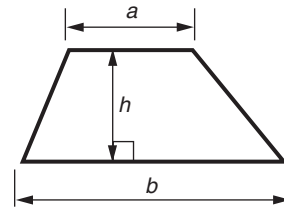

**Volume of prism** = (area of cross-section)  $\times$  length

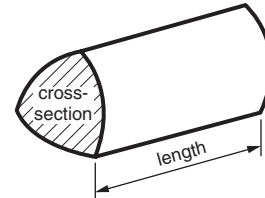

**In any triangle ABC**

**Sine rule**  $\frac{a}{\sin A} = \frac{b}{\sin B} = \frac{c}{\sin C}$

**Cosine rule**  $a^2 = b^2 + c^2 - 2bc \cos A$

**Area of triangle** =  $\frac{1}{2}ab \sin C$

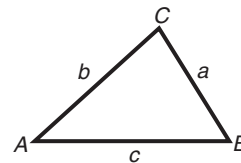

**Volume of sphere** =  $\frac{4}{3}\pi r^3$

**Surface area of sphere** =  $4\pi r^2$

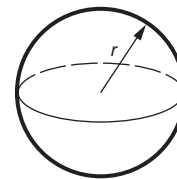

**Volume of cone** =  $\frac{1}{3}\pi r^2 h$

**Curved surface area of cone** =  $\pi rl$

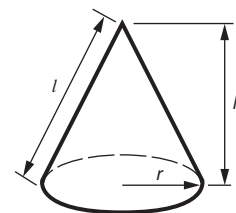

**The Quadratic Equation**

The solutions of  $ax^2 + bx + c = 0$ ,  
where  $a \neq 0$ , are given by

$$x = \frac{-b \pm \sqrt{b^2 - 4ac}}{2a}$$

**PLEASE DO NOT WRITE ON THIS PAGE**

Answer **all** the questions.

1 (a) Work out.

(i)  $-5 + -4 \times 3$

(a)(i) ..... [2]

(ii)  $\frac{-6 \times -4}{-3}$

(ii) ..... [2]

(b) (i) You are given that  $528 + 128 = 656$ .

Use this information to complete the following.

(b)(i)  $656 + \dots = 128$  [1]

(ii) You are given that  $16 \times 9 = 144$ .

Use this information to complete the following.

(ii)  $144 \times \dots = 16$  [1]

2 (a) Work out.

$$4^3 + \sqrt{196}$$

(a) ..... [2]

(b) Write these fractions as decimals.  
Give your answer correct to 3 decimal places.

(i)  $\frac{5}{8}$

(b)(i) ..... [1]

(ii)  $\frac{3}{7}$

(ii) ..... [2]

- 3 (a) Find the perimeter of this triangle.

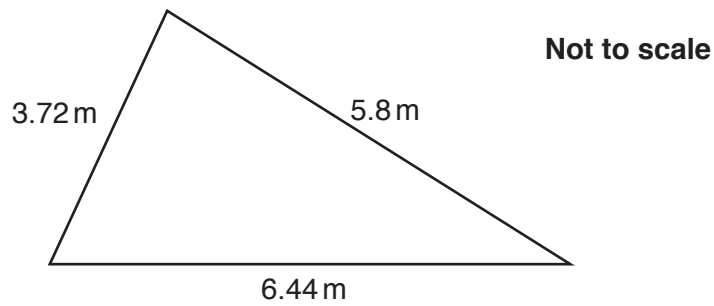

(a) ..... m [2]

- (b) A knife is 20.5 cm long.  
The blade is 11.8 cm long.

Find the length of the handle.

(b) .....cm [2]

- 4 (a) A row of blocks has a height of  $b$  cm.  
A wall with  $r$  rows of blocks has a height of  $h$  cm.

Write down a formula for  $h$ .

(a) ..... [1]

- (b) Apples cost £2 per kilogram and pears cost £3 per kilogram.  
The total cost of  $p$  kilograms of apples and  $q$  kilograms of pears is £ $C$ .

Write down, as simply as possible, a formula for  $C$ .

(b) ..... [2]

5 One week Tim earned £350.

He saved  $\frac{2}{5}$  of it.

(a) How much did he save?

(a) £ ..... [2]

(b) He then gave a donation to charity.

He spent  $\frac{1}{4}$  of the money he had left after he had made the donation.

The amount he spent was £50.

How much money did he give to charity?

(b) £ ..... [3]

6

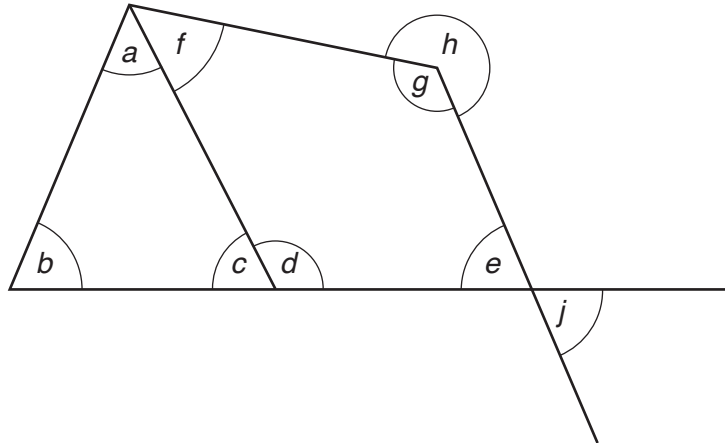

(a) Write down two equal angles stating why they are equal.

..... = ..... Reason ..... [1]

(b) Write down two angles that add up to  $180^\circ$  stating how you know they add up to  $180^\circ$ .

..... and ..... Reason ..... [1]

(c) Use a single letter to complete the following.

(c)  $a + b =$  ..... [1]

7 A is the point  $(-4, 1)$ , B is the point  $(p, q)$ .

(a) M is the point  $(1, -3)$ .

$$\overrightarrow{AM} = \overrightarrow{MB}.$$

Find the value of  $p$  and the value of  $q$ .

(a)  $p = \dots\dots\dots$ ,  $q = \dots\dots\dots$  [2]

The line  $y = \frac{1}{2}x + 3$  crosses the  $y$ -axis at D.

(b) C is the point  $(r, s)$  and  $\overrightarrow{AC} = 3\overrightarrow{AD}$ .

Find the value of  $r$  and the value of  $s$ .

(b)  $r = \dots\dots\dots$ ,  $s = \dots\dots\dots$  [2]

(c) The line DE is perpendicular to AD.

Find the equation of the line DE.

(c)  $\dots\dots\dots$  [2]



8

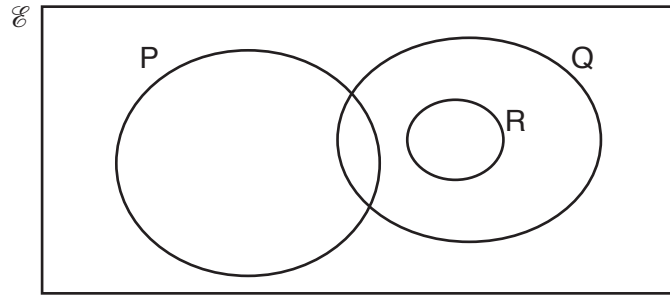

Complete these statements about sets P, Q and R.

- (a) R is a ..... of Q [1]
- (b)  $R \cup Q = \dots\dots\dots$  [1]
- (c)  $n(R \cap Q) = n(\dots\dots\dots)$  [1]
- (d)  $n(P \cup Q) = n(P) + n(Q) - n(\dots\dots\dots)$  [1]

9 (a) Factorise.

$$x^2 - x$$

(a) ..... [1]

(b) Simplify.

$$3a^2 - 5a + 2a + 5a^2$$

(b) ..... [2]

(c) Solve.

$$2(x - 1) = 6(x + 5)$$

(c) ..... [3]

10

10 Moeen has a bag of 20 tulip bulbs, of which 10 are red, 7 are yellow and 3 are orange. He picks two bulbs from the bag at random.

(a) Complete this tree diagram to show the possible outcomes.

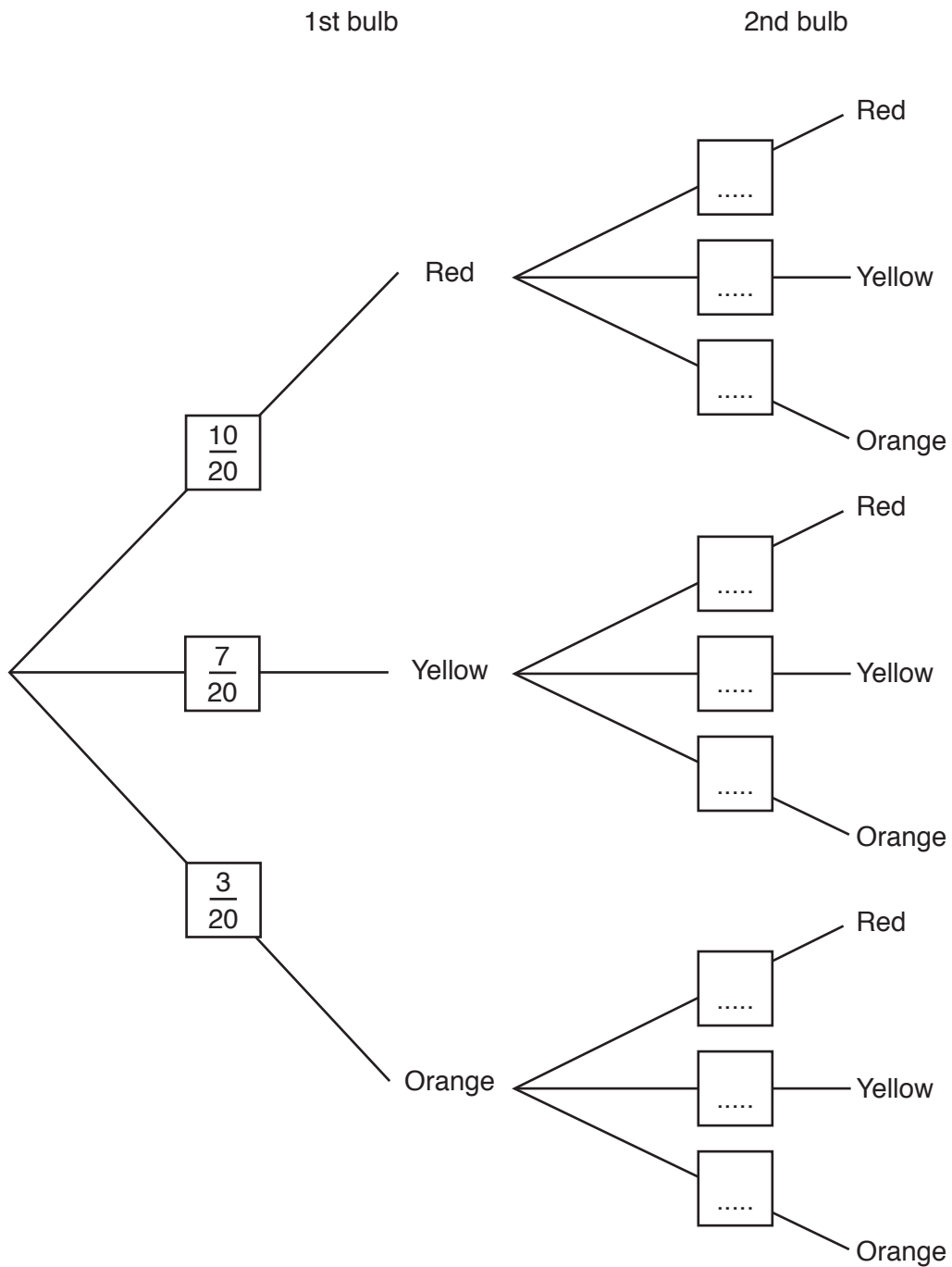

[3]

(b) Find the probability that the bulbs are

(i) both red,

(b)(i) ..... [2]

(ii) both the same colour,

(ii) ..... [3]

(iii) different colours.

(iii) ..... [1]

11

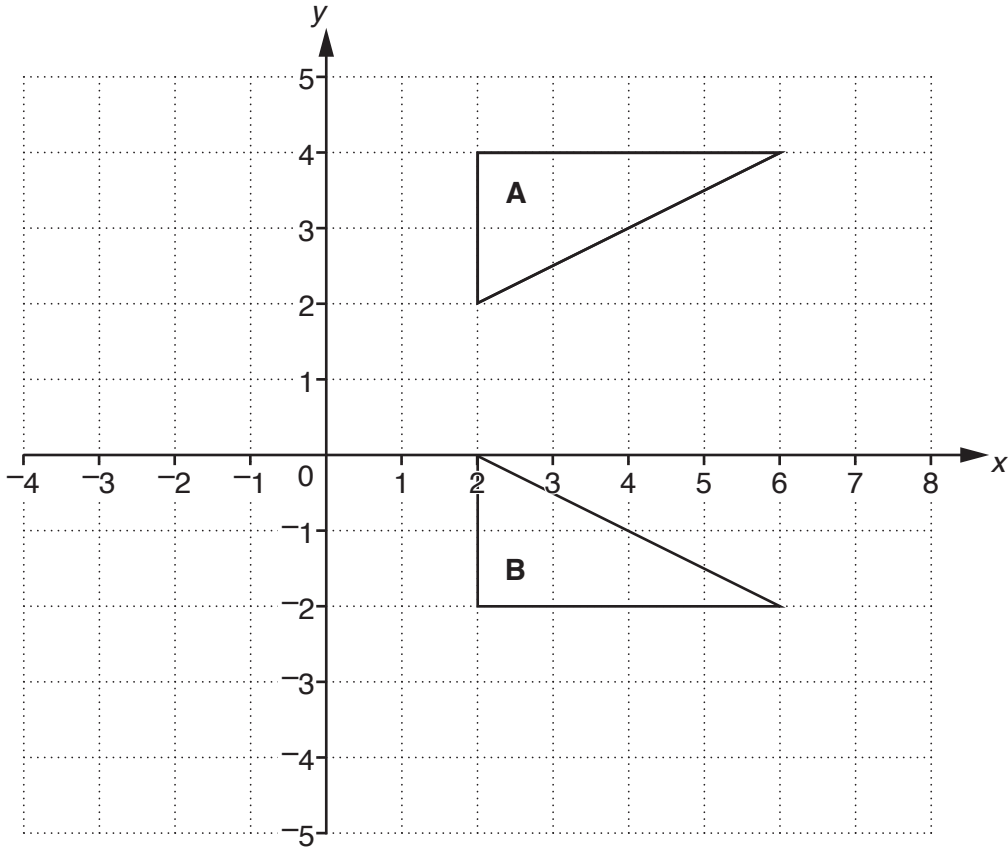

(a) Describe fully the single transformation that maps triangle **A** onto triangle **B**.

.....  
 ..... [2]

(b) Enlarge triangle **A** with scale factor  $-\frac{1}{2}$  and centre (0, 0). [2]

12\*

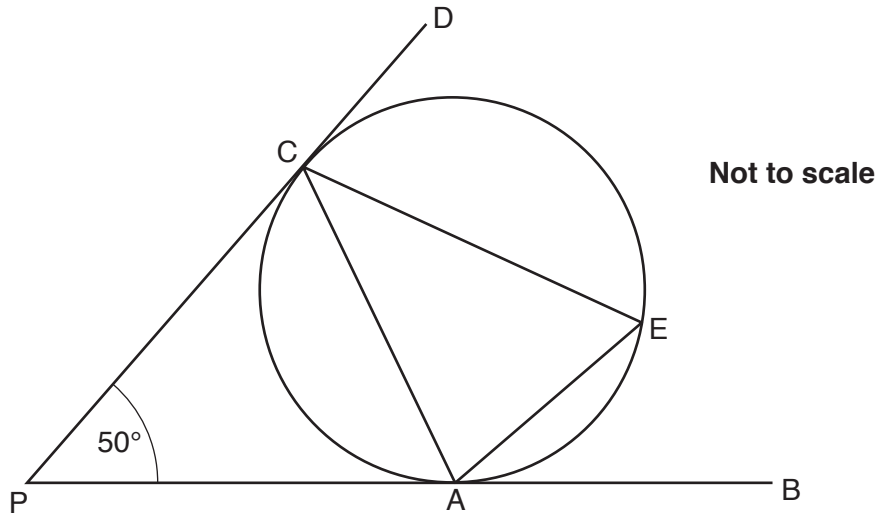

PAB and PCD are tangents to the circle at A and C.  
Angle APC =  $50^\circ$ .

Find angle AEC.  
You must show a reason for each step of your working.

.....

.....

.....

.....

.....

.....

Angle AEC = ..... [5]

**END OF QUESTION PAPER**

**ADDITIONAL ANSWER SPACE**

If additional space is required, you should use the following lined page(s). The question number(s) must be clearly shown in the margin(s).

A large area of lined paper for writing, consisting of 25 horizontal dotted lines. A solid vertical line runs down the left side of the page, creating a margin. The rest of the page is blank.

A grid of horizontal dotted lines for writing, with a solid vertical line on the left side. The grid consists of 25 rows of dotted lines, each row separated by a solid vertical line on the left. The lines are evenly spaced and extend across the width of the page.

A large rectangular area with a solid vertical line on the left side and horizontal dotted lines extending across the page, providing a space for writing answers.



**Copyright Information**

OCR is committed to seeking permission to reproduce all third-party content that it uses in its assessment materials. OCR has attempted to identify and contact all copyright holders whose work is used in this paper. To avoid the issue of disclosure of answer-related information to candidates, all copyright acknowledgements are reproduced in the OCR Copyright Acknowledgements Booklet. This is produced for each series of examinations and is freely available to download from our public website ([www.ocr.org.uk](http://www.ocr.org.uk)) after the live examination series.

If OCR has unwittingly failed to correctly acknowledge or clear any third-party content in this assessment material, OCR will be happy to correct its mistake at the earliest possible opportunity.

For queries or further information please contact the Copyright Team, First Floor, 9 Hills Road, Cambridge CB2 1GE.

OCR is part of the Cambridge Assessment Group; Cambridge Assessment is the brand name of University of Cambridge Local Examinations Syndicate (UCLES), which is itself a department of the University of Cambridge.